

---

# Extraterrestrial CPR and Its Applications in Terrestrial Medicine

---

Thais Russomano and Lucas Rehnberg

Additional information is available at the end of the chapter

<http://dx.doi.org/10.5772/intechopen.70221>

---

## Abstract

Cardiopulmonary resuscitation (CPR) is a well-established part of basic life support (BLS), saving countless lives since its first development in the 1960s. Recently, work has been undertaken to develop methods of basic and advanced life support (ALS) in microgravity and hypogravity. Although the likelihood of a dangerous cardiac event occurring during space mission is rare, the possibility exists. The selection process for space missions nowadays considers individuals at ages and with health standards that would have precluded their selection in the past. The advent of space tourism may even enhance this possibility. This chapter presents a synthesis of the results obtained in studies conducted at the MicroG-PUCRS, Brazil, examining extraterrestrial CPR during ground-based microgravity and hypogravity simulations and during parabolic flights and sustained microgravity. It outlines the extraterrestrial BLS guidelines for both low-orbit and deep-space missions. The former are based on a combination of factors, unique for the environment of space. In a setting like this, increased physiological stress due to gravitational adaptation and the isolated nature of the environmental demands can affect the outcome of resuscitation procedure.

**Keywords:** extraterrestrial CPR, microgravity, hypogravity, medical emergencies, cardiac arrest, BLS, space tourism, space missions, space medicine, space physiology

---

## 1. Introduction

Cardiopulmonary resuscitation (CPR) is a well-established part of basic life support (BLS) and has saved tens of thousands of lives [1] since its development by Peter Safar in the 1960s [2]. Terrestrial BLS guidelines are developed by national organisations, such as the American Heart Association (AHA), the European Resuscitation Council (ERC) and the International Liaison Committee on Resuscitation (ILCOR). The terrestrial method of performing CPR has

not changed significantly since it was first implemented, the locked straight-arm method with the rescuer accelerating their chest to generate the force needed to compress the victim's chest. Other aspects of the BLS guidelines often change and evolve as new evidence emerges, one example being the Chain of Survival, which has recently been updated [3]: (1) immediate recognition of cardiac arrest and activation of the emergency response system, (2) early CPR with an emphasis on chest compressions, (3) rapid defibrillation, (4) effective advanced life support and (5) integrated post-cardiac arrest care [4–6].

Changes in gravitational fields, such as those found in the microgravity of space and hypogravity of Mars or the Moon, pose several practical and logistical problems that will impact on the effectiveness of the CPR administered and affect the outcome for any patient who experiences a cardiac arrest in a space mission. In recent years, several studies have been undertaken to develop methods of basic and advanced life support (ALS) in microgravity and hypogravity, using ground-based simulations, parabolic flights or training for medical emergencies in actual space missions.

It is important firstly to understand some of the physics behind space life sciences. The gravitational force of the Earth, which produces an acceleration of approximately  $9.81 \text{ m/s}^2$  at mean sea level and is indicated by the symbol 'g' (small letter), has shaped the anatomy and physiology of human beings over millions of years. The concept of human body G vectors uses an axial nomenclature system that has been the basis for studies related to acceleration physiology since its introduction [7]. The three major axes are longitudinal (Z), lateral (Y) and horizontal (X). The direction of acceleration forces along the axes is called (+) or (-), but in general the positive sign is omitted. The inertial forces are opposite to the acceleration forces, as indicated in **Figure 1**. Therefore, when considering the effects of the G force on human physiology, it is important to indicate the axis and the direction of the acceleration force along it. For example, when a volunteer is performing terrestrial CPR manoeuvres, it is said that they are under the influence of 1 Gz.

It is a common misconception that gravity does not exist in space, either aboard space ships or space stations in lower earth orbit (LEO). Typical LEO ranges from between 120 and 360 miles above the Earth, and the gravitational field at this distance is still quite strong, roughly 88% of that felt at the Earth's surface. Therefore, what is often referred to as 'zero gravity' is in fact microgravity, an important difference to note, and the objects or astronauts seen to be 'floating' in space are in reality in a constant state of free fall. This means they are actually falling around the Earth at the same rate as the orbital speed of their spacecraft, which is approximately 17,500 miles/h (28,000 km/h), providing the same effect that would be given by real microgravity [9].

The prefix micro ( $\mu$ ) derives from the original Greek mikros ( $\mu\kappa\rho\rho\varsigma$ ), meaning small. A microgravity environment is one that imparts to an object a net acceleration that is extremely small compared with that produced by Earth at its surface, which can be achieved using various methods, including Earth-based drop towers, parabolic aircraft flights and Earth-orbiting laboratories. Exposure to microgravity has been shown to affect every single body system, and the resultant physiological changes can lead to undesirable health consequences [9, 10].

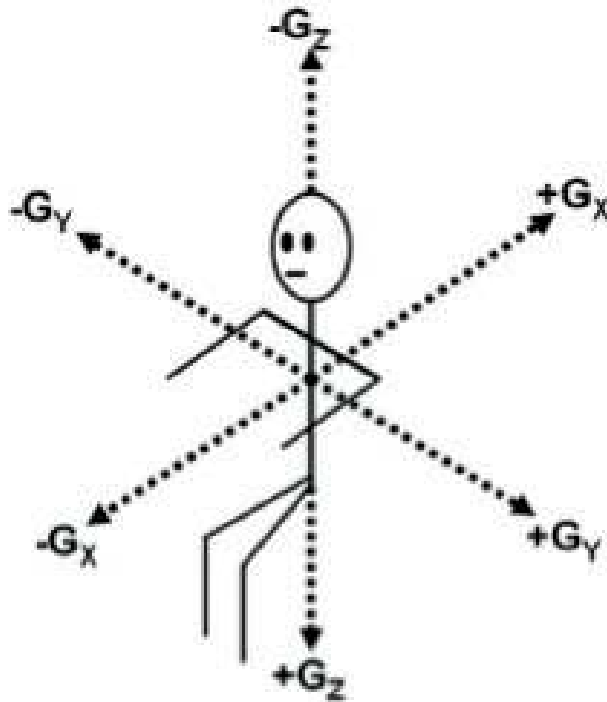

**Figure 1.** Standard acceleration nomenclature. Note that the arrows indicate the direction of the inertial reaction to an equal and opposite acceleration [7, 8].

The acceleration due to gravity at the surface of a planet varies directly as the mass and inversely as the square of the radius. The Moon is 384,403 km distant from the Earth, and it has a diameter of 3476 km. The acceleration due to gravity is 1.62 m/s<sup>2</sup> (1/6 of the Earth) because the Moon has less mass than the Earth. Mars and Earth have diameters of 6775 km and 12,775 km, respectively. The mass of Mars is 0.107 times that of the Earth. This makes the gravitational acceleration on Mars 3.73 m/s<sup>2</sup>, as expressed in Eq. (1):

$$g_m = 9.8 \times 0.107 \times (12775/6775)^2 = 3.73m/s^2 \quad (1)$$

Therefore, if a body weighs 200 N on Earth, it is possible to calculate how much it would weigh on Mars. Knowing that the weight of an object is its mass (m) times the acceleration of gravity, we can have  $W = m \times g$ ,  $200 = 9.8 \times m$  and  $m = 20.41$  kg. This mass is the same on Mars, so the weight on Mars is  $W_{Mars} = 3.73 \times 20.41 = 76.1$  N and  $m_{Mars} = 7.61$  kg.

Some of the physical principles of microgravity and hypogravity have been explained above to clarify some of the common terminology and misconceptions. Throughout this chapter, we will use the terms microgravity and hypogravity. When discussing microgravity, commonly referred to as ‘weightlessness’ by laypersons, we are referring to being in space either aboard

a space craft or aboard a space station and not on the surface of any extraterrestrial body. When talking about hypogravity, this relates to being on the surface of another extraterrestrial body (i.e. Mars, Moon) as these surfaces do have a gravitational field; however, they are weaker than that of Earth's.

This chapter will first present the effects of a space mission on human physiology, considering in particular cardiovascular and pulmonary function and their adaptation to the hostile environment of space. It will then discuss more than a decade of research involving a series of studies examining extraterrestrial CPR during ground-based microgravity and hypogravity simulations and during parabolic flights. It will also outline the essential CPR steps, in the form of extraterrestrial CPR guidelines, to be applied for both low-orbit and deep-space missions, such as a trip to Mars. The rationale behind the creation of specific guidelines for microgravity and hypogravity BLS and CPR is based on a combination of factors that render current traditional methods inappropriate for use in the unique environment of space, a setting in which the human body must adapt to altered gravitational conditions that lead to increased physiological stress, and where the isolated nature of the environment demands greater self-reliance, all of which may hinder a successful outcome when resuscitating a patient.

## **2. The effects of microgravity on human physiology and its impact on the cardiopulmonary system**

Physiological alterations suffered by astronauts during space missions have been observed, reported and studied from the beginning of manned space flight. The microgravity of space appears to affect every single organ and body system of the astronauts, in different intensities and manner, both during short- and long-term missions. The first men to remain in space longer than 24 h were Soviet cosmonauts Titov and Nikolayev in the 1960s. Postflight data collection revealed that the cardiovascular systems of the cosmonauts presented problems in readapting to the gravity of the Earth, with both exhibiting difficulties in maintaining arterial blood pressure levels when standing [9].

During the initial phases of the American space programme, NASA astronauts from the Gemini, Apollo and Skylab missions also showed deleterious signs and symptoms related to exposure to microgravity. Although these early ventures into the space environment were shorter than the missions nowadays, with the longest being a 3-month Skylab flight, it was already evident that the effects of microgravity on the human body would be very challenging. For example, astronauts presented decreases in plasma volume (around 10–20%); red blood cells (space anaemia); bone calcium levels (bone demineralisation); skeletal muscle size and strength (muscle atrophy), especially those that support posture (anti-gravitational muscles and bones); intestinal mobility; immune responses; and sleeping hours [10–13]. Most astronauts also suffered from space motion sickness, which is a common condition, affecting around 70% of astronauts during the first 72 h of a space mission, causing nausea, vomiting, dizziness and light-headedness and consequently decreasing physical and mental performance and overall well-being [14].

Moreover, very early in the manned space flight era, it became clear that the harmful effects on human physiology and anatomy would not be restricted solely to the time spent in microgravity. Important postflight alterations were also apparent after the return of astronauts to Earth's gravity, such as neurovestibular disturbances, orthostatic intolerance and reduced aerobic capacity [15].

## 2.1. Space cardiovascular physiology

A progressive shift of body fluids and blood from the lower extremities to the upper body occurs in the absence of Earth's gravitational force [16, 17]. Initially, this upward shift increases the central fluid volume, cardiac size (around 20%) and cardiac output. It then leads to a negative fluid balance and reduction of 12–20% in the circulating blood volume [17], which causes a decreased resting stroke volume of 10–20% and a reduced cardiac output with an average of  $1.5 \text{ L min}^{-1}$  lower than preflight values [18, 19]. These changes are secondary to the reduction in circulating blood volume [20].

This condition has been nicknamed the 'puffy-face and bird-legs syndrome', as the face of the astronaut becomes rounded, redder and more swollen, while the legs become thinner, due to the redistribution of fluids and blood from the lower to upper body. The situation is reversed when the astronaut is once more subject to the gravitational force of the Earth, which distributes the fluid and blood back to its original position [16, 21]. These stages of cardiovascular adaptation to microgravity and subsequent readaptation upon return to Earth are represented in **Figure 2**.

Arterial blood pressure and heart rate are more difficult to evaluate during a space mission. While some studies have demonstrated that microgravity can decrease both arterial blood pressure and heart rate [20, 22], others have shown that heart rate, for example, remains unchanged in microgravity [23]. Research is reporting average decrease of 15 bpm in flight resting heart rate and an average decrease of 6 mmHg in mean arterial pressure. These cardiovascular changes were observed when compared with preflight standing values and not supine [22]. In addition, the arterial blood pressure reduction occurred in diastolic values, while systolic blood pressure remained unchanged from that of preflight.

More recently, visual impairment intracranial pressure (VIIP) syndrome has been identified as a health issue occurring in astronauts who have stayed in microgravity for at least 6 months. This syndrome was first reported in 2005, when a refractive change in visual acuity (mainly hyperopia) was detected after a long-term space mission. This finding was further confirmed through evaluations conducted by means of a series of questionnaires applied to astronauts who took part in long space flight missions on the ISS [24]. Very little is known regarding the risk factors and pathophysiological mechanisms involved in space VIIP syndrome. The current consensus within the space flight community is that visual changes and eye alterations (papilloedema, posterior globe flattening, hyperopic shift, choroidal folds) are a consequence of raised intracranial pressures resulting in optic nerve sheath distension. This increase in optic nerve sheath diameter can readily be measured using a simple, non-invasive and low-cost ophthalmic procedure, resulting in an easy way to diagnose this medical condition [25]. However, other factors, such as increased levels of carbon dioxide in the spacecraft, genetic predisposition and ocular and/or brain structural changes secondary to microgravity could also be involved in the aetiology of this syndrome.

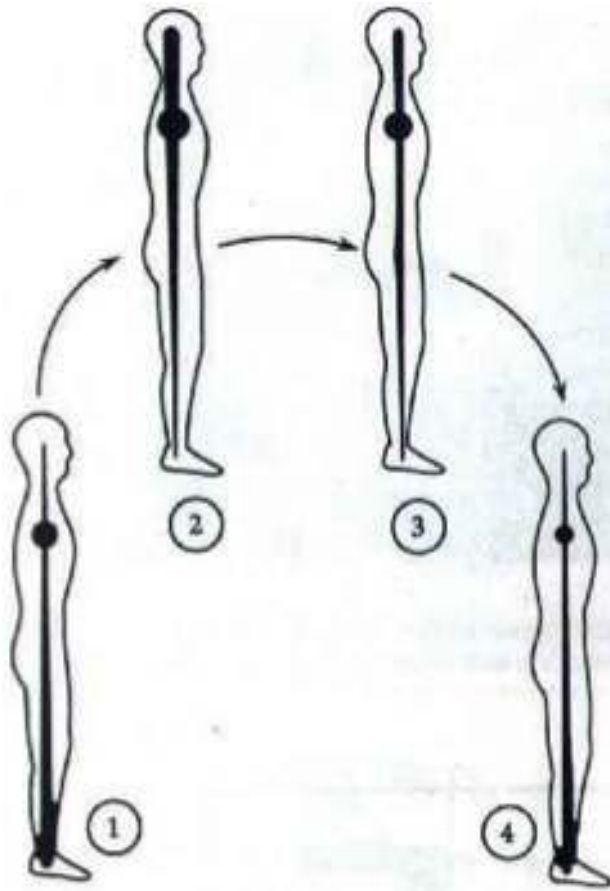

**Figure 2.** Schematic view of the blood and fluid distribution on Earth (1), after insertion into microgravity (2), during space adaptation (3) and upon return to Earth (4). Note that the puffy-face and bird-legs syndrome occurs in numbers 2 and 3 [16, 21].

Although no serious cardiac events in space have required resuscitation to date, the overall risk of potential cardiac deconditioning developing into a life-threatening illness is approximately 1% per year [26, 27]. Despite this low figure, some documented cases of astronauts presenting disturbances in cardiac rhythm have been observed, such as ventricular tachycardia and prolonged QTc interval after short- and long-duration flights. However, there is little compelling evidence from flight data that space causes cardiac dysfunction or life-threatening dysrhythmias [28, 29]. Ventricular arrhythmias were also reported during the second month aboard the MIR space station [30], and a loss of left ventricular mass was seen during the exposure to microgravity [31]. These factors combined could pose extra stress to the cardiovascular system and, in a worst-case scenario, lead to cardiac arrest [32].

## 2.2. Space respiratory physiology

Short- and long-term exposure to microgravity produces several effects on lung volumes, capacities and function, which have been assessed during space missions and parabolic flights, as well as in ground-based studies.

Evidence has shown that there is a 4 mm increase in the anteroposterior (AP) dimension of the chest wall at the level of the fifth intercostal space during microgravity exposure. This expansion can be explained by a decrease in weight of the abdominal wall, which allows the sternum to move in a cranial direction. As well as expanding the ribcage, this induces subsequent relaxation of parasternal intercostal muscles, further increasing the AP distance [33]. The effect of microgravity on chest anatomy was also observed during parabolic flights, whereby a displacement of the sternum in the cranial direction was found in microgravity, accompanied by an increase in diameter of the lower rib cage. This change in position of the chest wall was predicted to cause the volume-pressure curve to lie between the standing-upright and the supine-position curves, with the net result of a reduction in lung volumes. In five subjects studied in a KC-135 aircraft during parabolic flight, functional residual capacity decreased by 432 ml during exposure to the acute microgravity phase. Vital capacity also reduced from a mean value of 4.72 L at 1 G to 4.35 L at 0 G. Forced vital capacity and forced expiratory volume in 1 s were also decreased by an average of 2.5% in the 20 s of microgravity per parabola in a parabolic flight [34].

During the 9-day-long Space Life Sciences-1 space mission, forced vital capacity and forced expiratory volume in 1s were significantly reduced on flight day 2 due to the effect of sustained microgravity but were greater than preflight values at day 9. In comparison with standing preflight values, tidal volume was decreased by 15% (110 ml) in microgravity, and this reduction remained during the entire space flight. Functional residual capacity and expiratory reserve volume decreased significantly in-flight by 520 and 370 ml, respectively, when compared with preflight standing values. Residual volume was less during flight by 350 ml, when compared with standing control values. This 20% reduction in the residual volume was unexpected as it is normally fairly resistant to change. It is believed that lung volumes are affected by the changes in intrathoracic blood volume that occurs throughout a mission and by the alterations in respiratory mechanics and cranial displacement of the diaphragm and abdominal content that happens in the absence of gravity [35].

The gravitational gradient affects the distribution of ventilation and perfusion in the upright human lung. This uneven distribution of ventilation and blood flow within the lungs leads to variations in ventilation-perfusion ratios. Cardiogenic oscillations of CO<sub>2</sub> decreased to approximately 60% in amplitude in microgravity [36], and there was also a significant reduction in cardiogenic oscillations of nitrogen (to 44%) and argon (to 24%) in comparison to preflight standing values [37]. Possible causes of the residual inhomogeneity of ventilation include regional differences in lung compliance, airway resistance and the motion of the chest wall and diaphragm. Microgravity was expected to completely abolish apicobasal differences in perfusion, and its persistence is possibly related to other mechanisms not affected by gravity, such as central-peripheral differences in blood flow and interregional differences in conductance.

The diffusion capacity of the lung has been shown to increase by 62% in a parabolic flight study and by 28% in sustained microgravity when values were compared with preflight standing values [36, 38]. The standing-to-supine transition pre- and postflight caused a significant elevation in blood volume in pulmonary capillaries. Diffusing capacity of the membrane was unchanged preflight in the standing-to-supine transition and significantly elevated in-flight in comparison to standing (27%) and supine (21%). In microgravity, the capillary filling is uniform, which is associated with a large increase in the surface area of the blood-gas barrier. Consequently, the membrane-diffusing capacity is substantially raised. This suggests an absence of subclinical interstitial pulmonary oedema in microgravity, as had been previously speculated [38, 39].

The overall effect of acute and sustained exposure to microgravity, although affecting the respiratory system, does not cause any deleterious effects to gas exchange in the lungs. However, there is no current suitable method of accessing arterial blood in space. Consequently, at present, values for blood-gas tensions are usually derived from measurements of respiratory gas partial pressures. To this end, the earlobe arterialised blood technique for collecting blood-gas tensions has been considered for use in space [40]. Access to arterial blood analysis would allow better physiological evaluations and the management of clinical emergencies during space missions, resulting in increased safety for crewmembers.

### **3. Current cardiopulmonary resuscitation (CPR) practice in microgravity and hypogravity and its simulations on Earth**

Although the likelihood of a dangerous cardiac event occurring in a space mission at present is rare, the possibility exists. The selection process for space missions nowadays considers individuals at ages and with health standards that would have precluded their selection in the past. With increased age, less stringent health requirements, longer duration missions and increased physical labour, due to a rise in orbital extravehicular activity, the risk of an acute life-threatening condition occurring in space has become of greater concern. The advent of space tourism may even enhance this possibility, with its popularity set to rise over the coming years as private companies test their new technology. Therefore, space scientists and physicians will have a greater responsibility to ensure space travellers, whether professional astronauts or space tourists, are adequately trained and familiarised with extraterrestrial BLS and CPR methods.

It is currently estimated that the time between the occurrence of cardiac arrest and the performance of ALS on a secured patient during a space mission ranges between 2 and 4 min [41]. However, BLS guidelines highlight that failure of the circulation for 3 min will lead to cerebral damage and that delay, even within this time frame, will lessen the chances of a successful outcome. Therefore, the rate of decline of a patient who has suffered cardiac arrest is dependent, amongst other things, upon the immediate initiation of CPR and the provision and adequacy of such prior to the return of spontaneous circulation, should this be achieved [3].



### 3.1. Extraterrestrial CPR simulations

The main difference in CPR in hypogravity and microgravity compared to terrestrial CPR is the strength of the gravitational field. In microgravity, patient and rescuer are both essentially weightless. When thinking about the technique of terrestrial CPR, with the rescuer accelerating their chest and upper body to generate a force to compress the patient's chest, it is obvious that this cannot work in microgravity without significant aids. To this end, several microgravity CPR techniques have been developed and tested in parabolic flights [4, 42, 43] and during ground simulations, such as when using a body suspension device system, to test their efficacy [5, 44, 45].

#### 3.1.1. Body suspension device system

Many partial-gravity suspension systems have been designed and used since the Apollo program. The cable suspension method typically uses vertical cables to suspend the major segments of the body and relieve some of the weight exerted by the subject on the ground, thus simulating partial gravity. A body suspension device (BSD) system used to simulate both hypogravity and microgravity was developed by the Aerospace Engineering Laboratory, MicroG Centre, PUCRS, Porto Alegre, Brazil. It consists of carbon steel bars, 0.6 mm × 0.3 mm in thickness, which are shaped into a prism frame. It has a height of 2000 mm, with a base of 3000 mm × 2260 mm [46].

This BSD has been used to simulate microgravity by fully suspending a volunteer and CPR mannequin. A steel cross bar (1205 mm × 27.5 mm) was hung using reinforced steel wiring that gave it the ability to withstand up to 600 kg. A static nylon rope was attached to the steel wiring of the cross bar, with carabineers fastened at each end, which were clipped to the corresponding hip attachments of the body harness worn by the volunteer. A safety carabineer was also attached to the volunteer's back. **Figure 3(A)** and **(B)** illustrates how CPR methods can be studied during microgravity simulations on Earth [5].

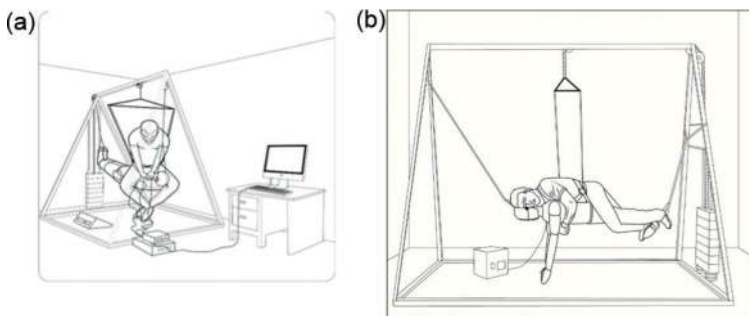

**Figure 3.** (a) The body suspension device system of the MicroG Centre, with the volunteer perpendicular and the CPR mannequin parallel to the floor, both being fully suspended, simulating microgravity. (b) The body suspension device system of the MicroG Centre, with both the fully suspended volunteer and CPR mannequin parallel to the floor, simulating microgravity.

Another way to simulate microgravity for the performance of CPR is placing the mannequin in the vertical position supported by a wall, which avoids the use of the rescuer body weight during the external chest compressions, as represented in **Figure 4**.

The BSD comprises of a body harness and counterweight system made of 20 bars of 5 kg each. Counterweights were used to simulate hypogravity by partially offsetting the effects of the +1 Gz environment in order to simulate Mars (0.35 Gz) or the Moon (0.16 Gz) gravities. Reinforced steel wire was used in a pulley system that connects the weights at the end of the body suspension device to the volunteer. A carabineer connects the steel wire to the attachment point on the back of the body harness (Fesp P100PGP). The manikin was positioned on the floor during the hypogravity simulation and +1 Gz [6, 46, 47]. **Figure 5** presents a schematic view of CPR being performed during ground-based hypogravity simulation.

The amount of counterweight used to simulate the hypogravity conditions, such as Mars or the Moon, was calculated for each volunteer based on their body weight, as presented in Eqs. (2) and (3) [46].

$$RM = (0.6BM \times SGF)/1G \quad (2)$$

$$CW = 0.6BM - RM \quad (3)$$

Using Eq. (2), the relative mass of a subject in a simulated gravitational field can be calculated, where RM = relative mass (kg), BM = body mass on Earth (kg), SGF = simulated gravitational force ( $m/s^2$ ) and  $1G = 9.81 m/s^2$ . Eq. (3) gives the counterweight (CW, in kg) necessary to simulate body mass at a preset hypogravity level. The 0.6 refers to the 60% of the weight of the upper body, as the legs are supported on the floor.

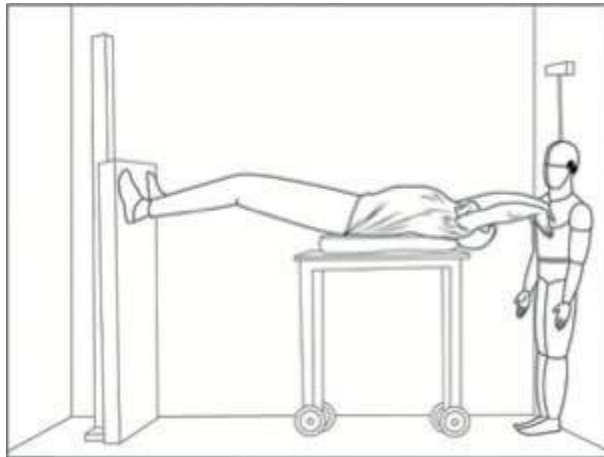

**Figure 4.** Microgravity simulation for CPR performance with the mannequin supported by a wall, in the vertical position, perpendicular to the floor. The volunteer is performing external chest compressions by flexing and extending his legs and therefore moving his body back and forth on top of a wheeled trolley.

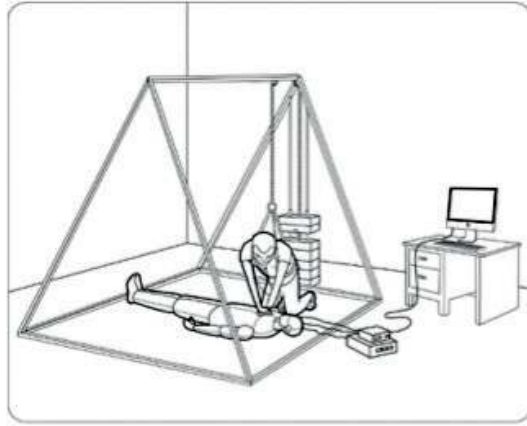

**Figure 5.** The body suspension device system of the MicroG Centre, with the CPR mannequin on the floor and volunteer assuming the terrestrial CPR position, being partially suspended through the counterweight system, simulating hypogravity.

For these ground-based hypogravity simulation studies, a standard CPR manikin (Resusci Anne Skill Reporter, Laerdal Medical Ltd., Orpington, UK) was modified to include a linear displacement transducer capable of measuring external chest compression (ECC) depth and rate. The steel spring located in the mannequin's chest depressed 1 mm with every 1 kg of weight applied to it. A real-time feedback of each ECC was provided to the volunteers via a modified electronic guiding system with an LED display. The LED display consisted of a series of coloured lights that indicated depth in mm of ECCs (red and yellow, too shallow; green, ideal). An ECC rate of 100–110 compressions/ $\text{min}^{-1}$  was established using an audio metronome. A 6 s interval between each ECC set represented the time taken for two mouth-to-mouth ventilations. Although not true to real life, by adding in these aids, it allowed standardisation of the volunteers as their experience and training in CPR varied.

### 3.1.2. Parabolic flights

Reduced gravity can be achieved with a number of technologies, each depending upon the act of free fall, such as drop towers, small rockets and parabolic flights. The latter is the only way to allow human subjects to be studied under conditions of microgravity or hypogravity. Therefore, many physiological and operational studies have been conducted by space agencies around the world in parabolic flights.

In parabolic flights, adapted airplanes execute a series of manoeuvres (parabolas), each providing around 20 s of reduced gravity (hypogravity) or weightlessness (microgravity), during which experiments can be performed and data collected. A typical NASA parabolic flight lasts 3 h and carries experiments and crewmembers. It climbs from an altitude of 7 km above sea level at a 45° (pull up) angle, traces a parabola (pushover) and then descends at 45° (pull out). Microgravity by means of free fall is experienced during the pushover phase. In the pull-up and pull-out segments, crew and experiments are subjected to hypergravity that ranges between 2 and 2.5 Gz [9].

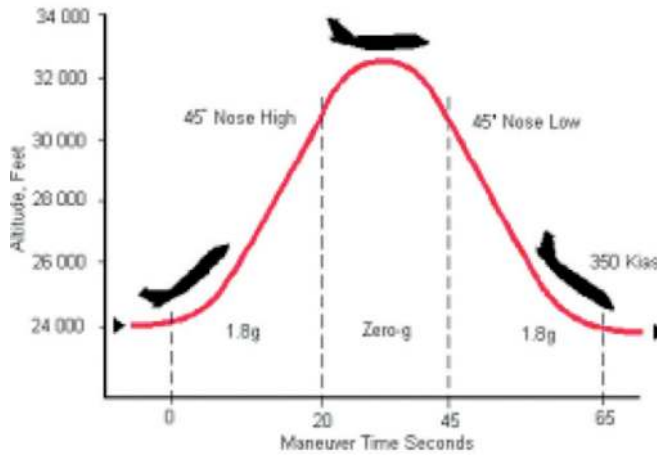

**Figure 6.** ESA parabolic flight profile, in which each parabola provides 20 s of microgravity that is preceded and succeeded by 20 s of hypergravity.

During a European Space Agency (ESA) campaign, there are typically 3 days of flights with 31 parabolas per flight. For each parabola, there are also two periods of increased gravity (approximately 1.8 Gz), which last for 20 s immediately before and after the 20 s of reduced gravity, as shown in **Figure 6**.

#### 4. Extraterrestrial CPR methods

Some of the challenges faced in this unique environment have already been presented, including the practical, logistical and physical. The physiological changes and increased physical demands that occur in an extraterrestrial environment make the performance of CPR already difficult, but add to this, the limited storage and parameters found on any spacecraft or orbiting station, such as the ISS, and the task become all the more daunting, especially if ill prepared. To this end, several methods of CPR have been developed to bridge the gap between the time of occurrence of a cardiac arrest and the time when further resuscitation equipment can be available. These methods focus in particular on the ability of a single person to apply CPR, in particular the Evetts-Russomano (ER), reverse bear hug (RBH) and handstand (HS) CPR methods.

The rationale for the development of these single-person methods is that in microgravity, whether in a spacecraft or space station, all equipment is stored away as cabin space is limited and equipment floating freely is hazardous. Thus, the time to elapse between a fellow crew-member recognising the need for retrieval and deployment of life support equipment could range anywhere from 2 to 4 min [41]. This time period is obviously a critical window that will affect patient survival, and therefore, to maximise the chances of a successful outcome, a single-person method of microgravity CPR is needed so chest compressions can begin while advanced life support equipment is retrieved.

Evidence regarding the applicability and suitability of the three single-person rescuer methods discussed in the next section is scarce and varies for several reasons. Parabolic flights have been used to research these methods [4, 42, 43], and although these flights provide an excellent microgravity analogue, the short periods of actual microgravity provided mean the data collected and the conclusions drawn from the results have limitations. The majority of the scientific data comes from ground-based analogues, wherein these unique CPR methods can be studied over longer periods of time. Nonetheless, it is difficult with these analogues to fully reproduce the microgravity environment and physiological changes usually seen in microgravity. As with all analogues, they are good but never a perfect replication of the actual environment.

#### **4.1. Evetts-Russomano CPR method**

The ER technique is the newest of the three methods to be discussed and perhaps the most technically difficult, potentially requiring more training of the individual than other methods to ensure its proficient application. The rescuer places their left leg over the right shoulder of the patient and their right leg around the patient's torso, allowing their ankles to be crossed approximately in the centre of the patient's back; this is to provide stability and a solid platform against which to deliver force, without the patient being pushed away (**Figure 7(A)**). From this position, chest compressions can be performed while still retaining easy access to perform ventilation. When adopting the ER method, the rescuer must be situated in a manner that also allows sufficient space on the patient's chest for the correct positioning of their hands to deliver the chest compressions.

It is important to note that the rescuer simply wrapping their legs around the patient's waist is not an adequate position; this will not provide a firm enough base, and the chest compressions applied will extend the patient's back and reduce the actual depth of the compressions.

The advantage of the ER position over other methods is that by being face-to-face with the patient, single-person ventilation is easier. Initial parabolic flight and ground-based simulation data showed the ER method as delivering an adequate rate and depth of chest compressions, although this was according to the 2005 resuscitation guidelines [5, 42]. More recent data from ground-based simulations, using the updated 2010 guidelines, demonstrated that rescuers using the ER method fell slightly below par in terms of depth of compression but were able to maintain an adequate rate [45, 47].

A disadvantage of the ER method lies in its being technically more difficult and potentially requiring the most amount of training in order to be effective. In addition, the ER method is fatiguing after 2 min of chest compressions following the current guidelines, being considered more tiring than the HS method, although less so than the RBH technique. It has been found that rescuer fatigue leads to a failure to decompress the chest completely. This is a common problem across all three methods as fatigue takes effect, but it is more pronounced with the ER method, and this may be in part due to the positioning of the rescuer [48].

Although there is no statistical data to support the idea, it has been observed and surmised by researchers that height and anthropometric measurements may not be a predetermining factor for successful chest compressions using the ER method. This signifies that a rescuer

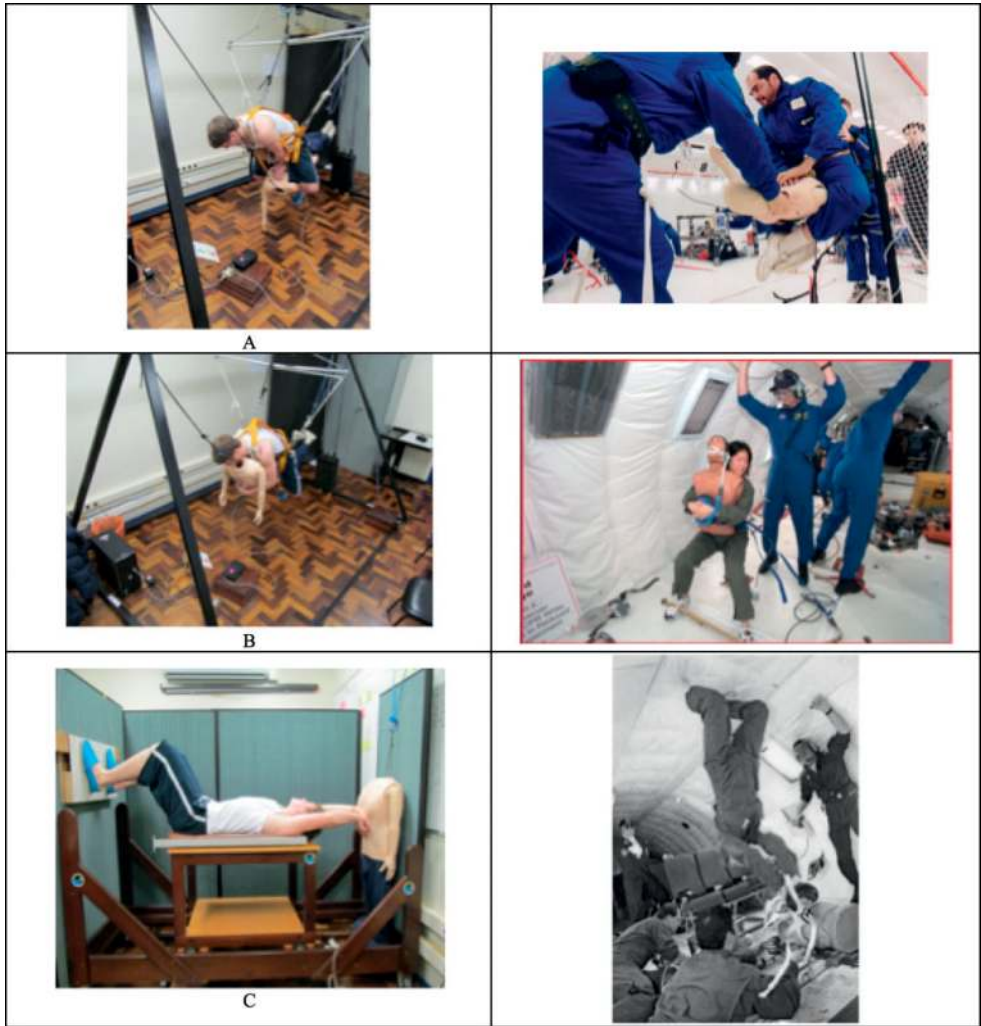

**Figure 7.** Three single-person microgravity CPR methods in ground-based microgravity simulations at the MicroG Centre and in parabolic flights: (A) Evetts-Russomano, (B) reverse bear hug and (C) handstand.

with short legs who may not be able to cross their ankles behind the patient's back may still be capable of performing CPR to an adequate standard using the ER method [5].

#### 4.2. Reverse bear hug CPR method

The RBH method is possibly the simplest of the three single-person methods presented and is essentially similar to the Heimlich manoeuvre. The rescuer needs no additional equipment or to be wary of their surroundings as the RBH method is independent of capsule parameters.

The rescuer takes up position behind the patient to easily wrap their arms around the patient and lock their hands across the patient's chest. Arm flexion is primarily used to produce the force needed for chest compressions. The rescuer can use their legs to stabilise both themselves and the patient (**Figure 7(B)**).

The advantage of the RBH method lies in its simplicity to learn and apply. The rescuer can easily assume a position behind the patient, find the correct spot on the patient's chest and begin chest compressions. Parabolic flight data has shown the RBH method to be an effective method of CPR in simulated microgravity [4]. However, when assessed during a ground-based analogue over a prolonged period of time, such as 2 min, the RBH fell dramatically short of the current resuscitation guidelines [45]. Despite the relative simplicity of the method, ground-based studies suggest that it is an ineffective and inefficient method when performed over time. CPR using the RBH was seen to initially provide an adequate depth and rate of chest compression, in accordance with the most recent guidelines. Nonetheless, as early as the second cycle of chest compressions, rescuers rapidly tired—resulting in a decline in the depth of chest compressions and overall drop in the quality of CPR [44, 45]. Logistically, this method also presents a problem in ventilating as the rescuer is positioned to the rear of the patient. Assuming the rescuer is alone, they would need to rotate the patient so they are face to face in order to provide ventilations, before rotating the patient back again in order to continue compressions. This manoeuvring would delay the resumption of chest compressions and ultimately affect the quality of the CPR applied.

### 4.3. The handstand CPR method

Performance of the HS method also requires no equipment, but the patient does need to be placed against the inner side of the capsule or spacecraft in which they are located. Importantly, this must be a solid surface that is capable of withstanding the force and vibration generated by the application of the CPR. Once a suitable site to position the patient has been identified, the rescuer must then place their feet on the surface opposite to the patient, having their arms stretched out above their head, as demonstrated in **Figure 7(C)**.

From this position, the rescuer can flex/extend their hips while keeping their arms straight and locked on the patient's chest in the traditional spot, to generate the force needed for chest compressions. Parabolic flights [4] and ground-based simulations [45] have found the HS method to be the least fatiguing of the three single-person CPR methods, with rescuers able to provide an adequate depth and rate of chest compressions, in accordance with the latest guidelines [4, 44, 45].

The major limiting factor of this technique is its reliance on the physical parameters of the vessel itself. The HS method is dependent on a capsule that is between a range of diameters in order to have sufficient space for the patient and rescuer, as well as enough distance between the two to allow sufficient hip and knee movement in order to generate enough force for chest compressions. Furthermore, the height of the rescuer is crucial with this method; a shorter rescuer may not be able to achieve good placement of the feet on the surface opposite to the patient, thereby being unable to generate enough force and resulting in inadequate chest compressions.

#### 4.4. Restrained CPR method: standard position

The restrained CPR method using the standard position is identical to that of terrestrial CPR but requires the use of equipment to restrain both the rescuer and the patient to prevent both from floating away from each other after the delivery of force. The restraint system currently used aboard the ISS is known as the crew medical restraint system (CMRS). The patient rests on the CMRS, which is used to strap the patient into a supine position. The standard technique, as the name suggests, is the same conventional CPR technique used on Earth. The difference lies in the rescuer having straps around their waist and a restraint cord across their lower legs (**Figure 8**). Researchers conducted in parabolic flights have shown this method to require a great deal of effort on the part of the rescuer, as they must counteract the force of the chest compressions. Thus, this method was seen to fatigue the rescuer quickly, even more so than the single-person HS method [4, 43].

#### 4.5. Restrained CPR method: straddling position

In the straddling manoeuvre, the rescuer performs chest compressions by kneeling across the patient's waist but uses the same retraining equipment as with the standard technique. The delivery of the chest compressions is the same as that of terrestrial CPR, in that arms are kept straight and placed on the chest. The advantage of this position over the standard technique is that it requires less space. The standard position requires an area large enough for both the CMRS and rescuer to fit side by side, whereas the rescuer is positioned above the patient in the straddling technique, thereby reducing the total space in use. This could be an important factor to consider, given the limited dimensions of a spacecraft or the ISS. Despite the familiarity and



**Figure 8.** Crew medical restraint system (CMRS) being tested in a parabolic flight (A) and at the international space station (B) [43].



relative ease of use of these techniques, parabolic flight data has indicated that CPR performed using both restraint methods fall below current AHA guidelines, suggesting they may not be the most appropriate method to use in the event of a cardiac arrest scenario on board [43].

## 4.6. Hypogravity CPR methods

### 4.6.1. Terrestrial-style hypogravity CPR

In hypogravity, sufficient gravitational field is present on most celestial bodies that humans could encounter (Moon or Mars), meaning that CPR could begin without any adjuncts or equipment. Unlike the conditions for administering CPR in microgravity, the presence of at least some gravity in these environments makes CPR feasible with traditional terrestrial CPR. However, the technique of CPR may need adjustment to counter the negative impact of the reduced gravitational field. Traditional CPR instruction advises the use of straight, rigid arms placed on the patient's chest to perform compressions. However, a reduction in the upper body weight of the rescuer due to a reduced gravitational field will lead to a decreased ability to generate force through acceleration of the upper body and the subsequent transfer of that force through the straight arms. Research has shown that a natural tendency to adapt takes place, seeking to generate more force by flexing/extending the upper limbs in order to augment acceleration of the upper body [46]. In instances where traditional CPR in hypogravity is not sufficient to generate enough force to achieve the necessary depth of chest compressions, rescuers are encouraged to have a combined technique of accelerating their upper body and extending their upper limbs to generate enough force to compress the chest to 50–60 mm [45, 47].

### 4.6.2. The seated arm-lock (SeAL) method

The seated arm-lock (SeAL) method is a new concept but has many similarities to the traditional CPR technique used for hypogravity [49]. It was devised as a means of combatting the potential negative issues caused by performing CPR in hypogravity. The SeAL method involves the rescuer straddling the patient, with the patient's arms being locked in behind the rescuers' knees. The rescuers' knees should be positioned in the shoulder area of the patient and their toes by the patient's hips (**Figure 9**). When used in a low-gravitational-field environment, the position prevents the rescuer from being pushed away from the patient by using the arms as a secure and comfortable pivot point. No residual tone is required in the patient's arms.

A small preliminary study found that rescuers were able to produce adequate depth of chest compression across a range of gravity conditions, Earth (1 Gz), Moon (0.38 Gz) and Mars (0.16 Gz). Additionally, the authors suggest that the SeAL method will allow the rescuer to be better secured to the patient and therefore prevent the two from being pushed apart from each other [49]. A preliminary study has recently been conducted at the MicroG-PUCRS, Brazil, testing a variation of this technique, called the Mackaill-Russomano hypoG CPR method. This adaptation of the SeAL technique sees the rescuer straddling the mannequin (CPR victim) and using their legs to embrace the legs of the dummy to act as an anchor. The weight of the mannequin legs were calculated and adapted to be in accordance with the gravitational force of the hypoG environment being simulated.



Figure 9. The seat arm-lock method in simulated hypogravity at the European Astronaut Centre.

## 5. Summary of ground-based space analogue studies

### 5.1. Microgravity CPR studies

Research into extraterrestrial CPR, particularly CPR in microgravity, has been ongoing for more than a decade. Several parabolic flight campaigns [4, 42, 43] have investigated the feasibility of the main CPR methods. As previously mentioned, although parabolic flights provide an excellent analogue of microgravity, their short duration (about 20 s per parabola) limits the amount of data that can be collected and interpreted. Accordingly, most of the available evidence investigating the different CPR methods has come from ground-based simulation studies, using such devices as the BSD. Although still with limitations, ground-based simulation studies do provide additional insight into the effectiveness and feasibility of microgravity CPR methods, particularly over prolonged time periods. Resuscitation guidelines are in general updated every 5 years, with adaptations made based on current evidence. This requires that CPR research in simulated extraterrestrial environments be periodically re-evaluated to determine if the various methods continue to meet current guidelines.

Earlier studies examining the ER method showed it could be administered and comply with the 2010 CPR guidelines while also correlating with parabolic flight data, indicating its use could provide effective CPR in microgravity. In addition, the research aimed to evaluate the physiological impact of performing the ER method, using subjective (Borg scale) and objective measurements (heart rate). Although found to be very tiring in comparison to terrestrial CPR, the ER method could be sustained effectively for up to 2 min [5]. Building on this work, comparative studies were conducted of the three main single-person CPR techniques, the ER, RBH and HS methods. A preliminary study comparing these methods proved the suitability of the BSD for conducting this type of research, which then led to a larger study. Results from

the larger comparative study, carried out using the 2010 guidelines, found the HS method to be the most effective in terms of depth (also called 'true depth' to account for adequate decompression of the chest during ECC) and rate of administered ECCs, closely followed by the ER method, while the RBH gave the worst clinical results, as well as being extremely fatiguing (**Figures 10 and 11**). These studies also assessed the physiological cost of performing these methods, compared to terrestrial CPR. Using more objective measures, such as oxygen uptake ( $\text{VO}_2$ ), these studies demonstrated that all three methods had a greater  $\text{VO}_2$  than terrestrial CPR, with the HS being the least aerobically demanding and the RBH the most demanding [44, 48].

The physiological challenge of these methods is potentially a very important issue, as a well-documented decline in  $\text{VO}_{2\text{max}}$  occurs when in microgravity for a prolonged period, even when using countermeasures. These ground-based studies, which aim for 50–60 mm compression depth in accordance with both the 2010 and 2015 resuscitation guidelines, highlight the significant increase in  $\text{VO}_2$  that takes place, when compared to the 2005 guidelines. These findings emphasise the importance of maintaining aerobic capacity in case the need to perform CPR in microgravity should arise [47, 50].

A series of studies have considered muscle activation, via superficial electromyography (EMG), while performing CPR in micro- and hypogravity, in order to understand the muscle groups used in comparison to terrestrial CPR. The rationale behind this was to potentially identify the responsible muscle groups so as to tailor exercise programs to ensure these muscle groups are maintained [6, 51, 52]. EMG data showed the triceps, pectoralis major and rectus abdominis muscles to be more active when conducting microgravity CPR, particularly for the ER method, when compared to 1 Gz and hypogravity CPR. This data adds to the evidence found in other studies indicating that astronauts need to maintain their muscle endurance in these particular muscle groups, as well as preserve their cardiorespiratory capacity to be able to adequately perform CPR should they need to in an emergency [52].

## 5.2. Hypogravity CPR studies

The BSD has also been successfully used in a series of studies evaluating CPR in simulated hypogravity. These studies have focused on the feasibility of performing CPR using the terrestrial method in hypogravity, as well as assessing the alterations in technique in hypogravity, physiological impact and weight as a pivotal factor in performing CPR in these environments. Initial hypogravity studies showed that CPR in hypogravity, particularly Lunar and Martian environments, was feasible using traditional terrestrial CPR. Furthermore, they highlighted the occurrence of an increase in the arm flexion angle of the rescuer [46]. Traditional teaching of BLS and CPR advocates that arms should be kept rigid in order to transfer the force of acceleration of the rescuers' upper body to the chest of the patient. These studies show that for CPR to be effective, and achieve guideline recommendations, the rescuer needs to flex and extend their arms, up to  $14^\circ$  ( $\pm 8.1^\circ$ ), and use their upper limb musculature to generate force to compress the chest to a sufficient depth. This was even greater in microgravity using the ER method, up to  $16.5^\circ$  ( $\pm 10.1^\circ$ ); however, as the technique used is markedly different to terrestrial CPR, a direct comparison between the two is difficult [46, 47, 50] (**Figure 12**).

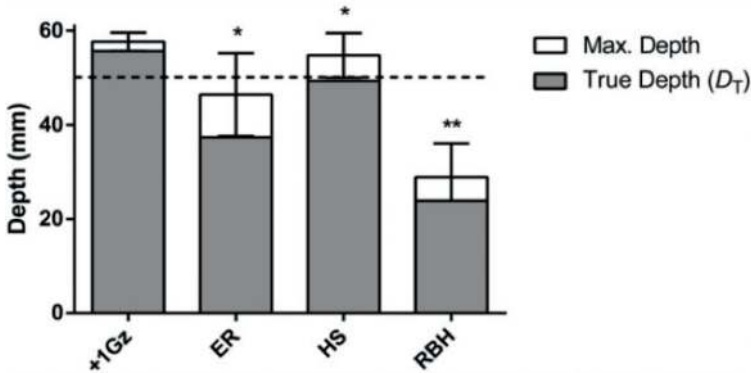

Figure 10. Mean true depth of ECC over 1.5 min for terrestrial and microgravity CPR using the three methods. Dashed line represents greater than 50 mm of depth set by the ILCOR 2010 guidelines; n = 23. Adapted from Ref. [48].

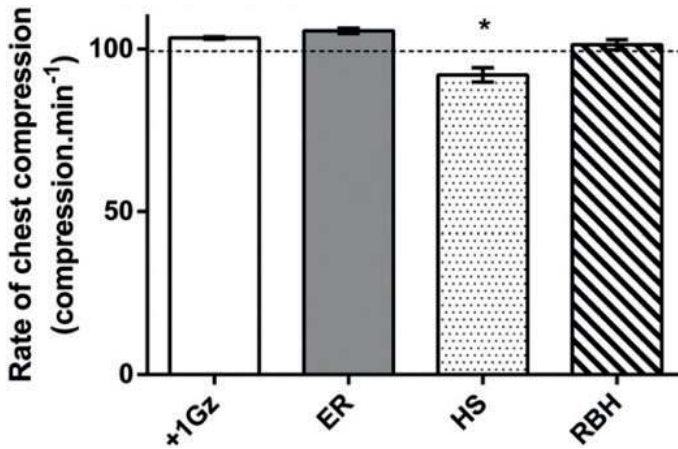

Figure 11. Mean rate of external chest compression (6 SEM) over 1.5 min for terrestrial and microgravity CPR using the three methods. Dashed line represents the lower limit of 100 compressions/min set by the ILCOR 2010 guidelines; n = 23. \* Significantly different from +1 Gz, ER and RBH. Adapted from Ref. [48].

Similar to the microgravity studies, the physiological cost was measured subjectively and objectively, using the Borg scale and  $VO_2$ , respectively. Compared to terrestrial CPR, hypogravity CPR is more tiring and requires a greater  $VO_2$ , but not to the same extent as the microgravity CPR methods [47] (Figure 13). EMG hypogravity CPR studies have shown the occurrence of more muscle activation in the rectus abdominis compared to +1 Gz CPR, as the rescuer needs to accelerate their upper body faster to generate the same force as would be found at +1 Gz. Considering Newton’s second law of motion,  $F = m \times a$ , a reduction in mass will require an increase in acceleration to maintain the same force.

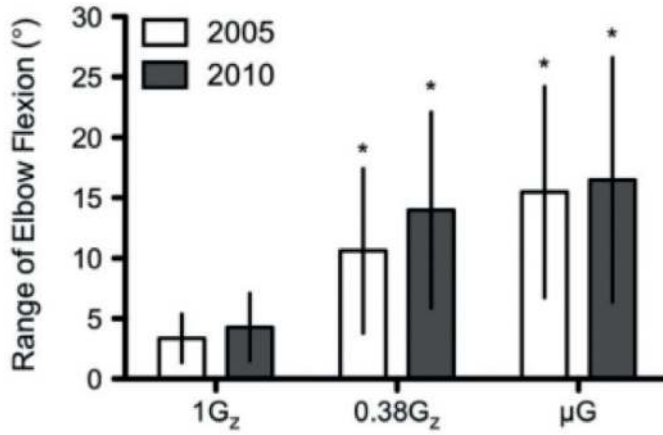

Figure 12. Mean ( $\pm$ SD) range of elbow flexion in the dominant arm at +1 Gz, 0.38 Gz and microgravity. Adapted from Ref. [47].

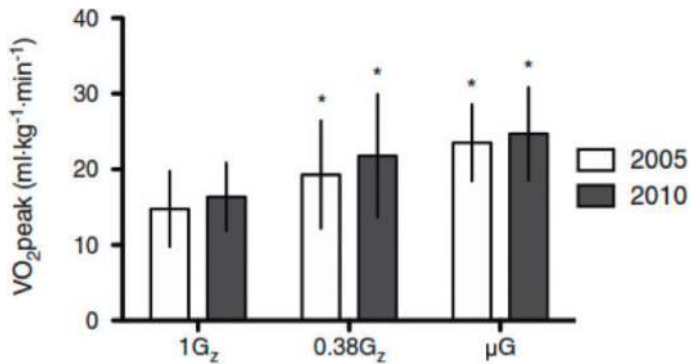

Figure 13. Peak oxygen consumption (VO<sub>2</sub>peak) at +1 Gz, +0.38 Gz and microgravity.

Hypogravity studies have considered weight and gender and their importance in performing CPR in these reduced gravitational fields. As the data shows, the more you effectively reduce the rescuers' body weight or possibly muscle mass, the harder it is to generate force for ECC, and therefore the more tiring it becomes. As greater numbers of females join the astronaut corp, it is important to address the differences in weight and muscle mass to determine how pivotal they are in performing CPR in hypogravity. These studies demonstrated the possible existence of a gender difference in the effectiveness of BLS when delivering ECCs, according to the 2010 guidelines.

Female subjects were more likely to perform inadequate ECCs, as they tended to be shorter, weigh less and possibly have a smaller muscle mass than the males. Moreover, they were

shown to have a higher physiological demand when performing ECCs. This was compared to males when performing CPR in hypogravity. Even when males had an effective reduction in their weight, they were still able to generate enough force to produce adequate depth and rate of ECC. This indicates that weight is not the only factor in effective ECC and that muscle mass may play an important role that counterbalances low-weight situations. Therefore, female rescuers may require additional strength training and alternative CPR techniques to overcome their lower bodyweight and muscle mass to ensure they can perform adequate ECCs in accordance with the current CPR guidelines [47, 50].

## 6. Extraterrestrial CPR guidelines

The extraterrestrial CPR guidelines presented in this chapter are based on the experience of the authors who conducted several studies at the MicroG-PUCRS, Brazil, and an extensive revision of the literature related to this topic. Therefore, the rationale behind specific guidelines for microgravity and hypogravity BLS and CPR is a combination of the novelty of the environment, increased physiological stress and isolated nature of these environments, all of which can affect the success of resuscitating a patient. However, familiarity and training of the appropriate BLS protocols and novel CPR methods for these environments will be a great benefit for both rescuer and patient. Furthermore, with the popularity of space tourism set to increase over the coming years, as private companies test new technology, there is a responsibility of space scientists and physicians to make sure that participants are familiar with and adequately trained in these novel BLS and CPR methods. Laypersons on Earth, such as schoolteachers and civil servants, learn BLS and CPR for a variety of reasons, and this custom should also apply to space tourists, who should be encouraged to become familiar with extraterrestrial resuscitation techniques. Therefore, extraterrestrial CPR guidelines have been developed and designed for all adults who will, for example, experience microgravity or hypogravity as part of their professional careers when participating in parabolic flights and space missions or who are involved in the training of astronauts.

Once cardiac arrest has been recognised, external chest compressions and ventilations need to be started immediately to maximise chances of survival. The best evidence for depth and rate of chest compressions come from international guidelines that are updated every 5 years by the International Liaison Committee on Resuscitation (ILCOR), who suggest changes to the European Resuscitation Council (ERC) and American Heart Association (AHA) based on the best possible evidence. Despite the well-documented altered physiology of astronauts in microgravity, there is insufficient evidence to suggest altering any of the parameters set by these international guidelines.

Summary of terrestrial ERC Guidelines for resuscitation (2015):

- Ratio of 30:2 (compression/ventilation).
- Rate of chest compression of  $100 \text{ min}^{-1}$  (but not exceeding  $120 \text{ min}^{-1}$ ).
- Depth of chest compression between 5 and 6 cm.

- Ventilation should be 500–600 ml during CPR and given over 1 s; both breaths should take NO longer than 5 s to prevent interruptions to chest compressions.
- If there are more than one rescuer or ventilation equipment available, 10–12 breaths should be given every minute or one breath every 5 or 6 s, each delivered over 1 s. Observe for visible chest rise.

The specific guidelines for chest compressions in microgravity and hypogravity remain the same on Earth:

1. Compress the chest at a rate of 100–120 min<sup>-1</sup>.
2. Each time compressions are resumed, place your hands without delay in the centre of the chest.
3. Pay attention to achieving the full compression depth of 5–6 cm (for an adult).
4. Allow the chest to recoil completely after each compression.
5. Take approximately the same amount of time for compression and relaxation.
6. Minimise interruptions in chest compressions.
7. Do not rely on a palpable carotid or femoral pulse as a gauge of effective arterial flow.
8. ‘Compression rate’ refers to the speed at which compressions are given, not the total number delivered in each minute. The number delivered is determined not only by the rate but also by the number of interruptions to open the airway, deliver rescue breaths and allow automatic external defibrillator (AED) analysis.

Chest compression-only CPR is important during resuscitation as it will benefit those who are not fully trained or are unwilling to perform mouth-to-mouth rescue breaths; this applies more to those who are entering hypogravity or microgravity as space tourists because all astronauts receive suitable BLS training. Under no circumstances should chest compressions be sacrificed for ventilations. Evidence suggests that compressions are more essential than ventilations during CPR and thus should be favoured during resuscitation [53]. There is no evidence to suggest that a change in ratio would be of benefit in hypogravity or microgravity. Therefore, rescuers should still aim for a ratio of 30:2 with a rate of compressions at 100 compressions min<sup>-1</sup> and a depth of 5–6 cm, as stated above.

With regard to the depth of chest compression, it can be affected by the expansion of the chest in microgravity. There is no specific evidence to support changes to the terrestrial guidelines; however, it is theorised that a change in the chest wall dimensions of a patient in microgravity may alter the requirements for effective delivery of CPR, meaning that 5–6 cm may not be a sufficient depth of compression and a depth of >6 cm may need to be considered. However, more evidence is needed before contemplating any important change in these guidelines.

Currently, there is little supporting evidence for the best practice of ventilation in either hypogravity or microgravity. There is no reason to suppose that this would be different in a hypogravity environment, compared to terrestrial CPR. As the technique of CPR is essentially the

same for both conditions, the rescuer should be equally capable of providing ventilations to the patient. The only caveat to this is if the patient and rescuer are in spacesuits, either while performing an extravehicular activity or walking on the surface of a planetary body, as the suit will obviously prevent them from giving mouth-to-mouth ventilation or administering CPR. However, future research into hypogravity BLS should evaluate the practicality of providing ventilations. With respect to microgravity, some research involving parabolic flight studies [4, 42] has evaluated ventilation, as well as chest compression depth and rate of these CPR methods. Findings have shown that rescuers using the Evetts-Russomano method were able to provide adequate ventilations of  $491 \pm 50.4$  ml, in accordance to the 1998 ERC guidelines that applied at the time [42]. Other research focusing on the use of ventilation adjuncts, which required the mannequin to be intubated with a Kendall CardioVent device, showed that a lone rescuer could provide adequate chest compressions with the ventilation adjunct. However, setting up this equipment as a lone rescuer would delay the beginning of chest compressions and would go against the new guidelines, C-A-B, where compressions take priority [4].

Throughout these guidelines the patient refers to the individual who has a suspected cardiac arrest, and the rescuer refers to the person who is immediately responsible for their resuscitation. The initial sequence in determining if the patient is responsive remains very similar to the ERC 2015 CPR guidelines but takes into account the communication and resource limitations whenwnments (**Figure 14**):

- Check if you and other crewmembers are safe. If environmental factors are likely to be the precipitating factor (failure of life support systems, toxin build-up, trauma from projectile), make sure these are no longer a threat to you and other crewmembers before attempting to rescue the patient.
- Check for response—gently shake shoulders, and ask loudly in each ear, ‘Can you hear me?’ or ‘Are you all right?’
- If patient does respond:
  - Find a suitable place to secure the patient to avoid risk of floating and suffering further trauma or leave them in their present position if no alternative is available.
  - Seek help from crewmembers, and attempt to determine what is wrong with the patient.
  - Reassess regularly until help arrives or communication is established with mission control/flight surgeon.
- If patient does not respond:
  - Shout for help immediately; when help arrives instruct them to find resuscitation equipment and more help. However, do not wait until they return; you must immediately begin chest compressions.
  - Follow the C-A-B sequence (compressions, airway, breathing).
  - Start chest compressions, selecting the appropriate CPR method depending on the environment you are in.



- The lone rescuer should begin CPR with compressions rather than two ventilations to prevent any delay in giving the first compressions.
- Emphasis is placed on the lone rescuer beginning compressions before checking the airway, again to prevent any delay in chest compressions.
- If the patient is responsive and breathing normally:
  - Place in a safe position.
  - Send or call for help—call crewmembers or mission control.
  - Reassess the patient regularly.
- If they are not breathing:
  - Seek someone for further help, and establish communication with mission control. Further resuscitation and AED are required.

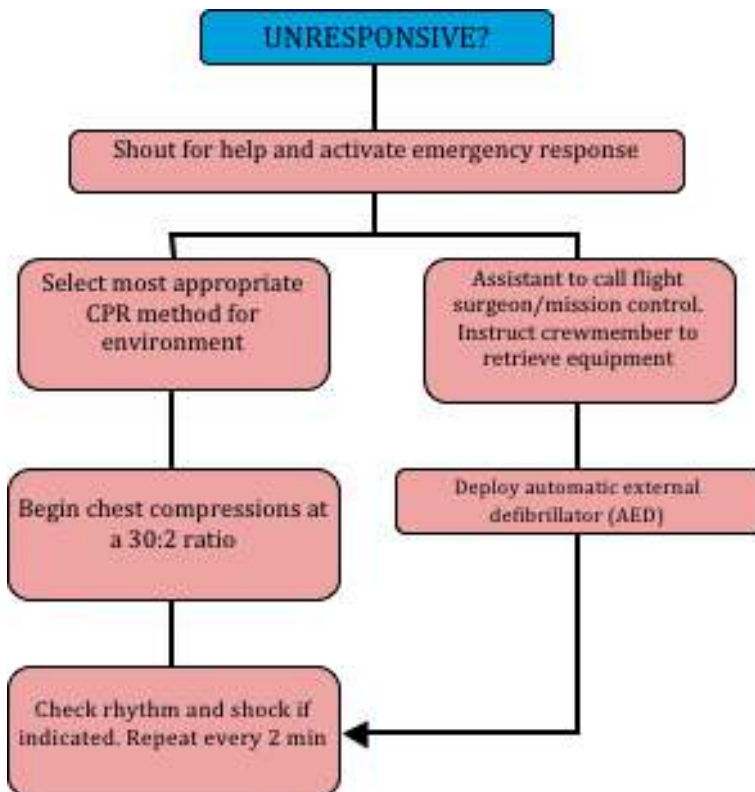

**Figure 14.** Microgravity and hypogravity adult basic life support algorithm, adapted from ERC 2010 guidelines. Reflect on the updated sequence of steps from airway, breathing and compressions (ABC) to compressions, airway and breathing (CAB).

- Start chest compressions, selecting the appropriate method depending on the environment you are in.

There is insufficient evidence, especially for the SeAL technique, to say which method is superior in hypogravity. However, it is recommended that the traditional terrestrial CPR method should be implemented first, as it produces adequate depth of compression with low levels of fatigue, suggesting that traditional CPR with an increased elbow flexion is an effective method of CPR [47]. **Figure 15** presents the algorithm for CPR to be applied in hypogravity environments.

### 6.1. Risks to rescuers

Altered physiology in microgravity and greater susceptibility to fatigue due to deconditioning could potentially affect the quality of CPR. The main factors that need to be considered are:

- Reduced gravitational field requires greater amount of force to be generated by the rescuer, resulting in increased muscle strain and shortness of breath in comparison to Earth.
- Deconditioning due to prolonged exposure to microgravity and/or hypogravity can place rescuers in a suboptimal physiological state when attempting to perform CPR. This could result in both a poor CPR performance and significant and rapid onset of fatigue.

Research examining CPR performance in simulated microgravity has shown all methods to be more fatiguing compared to terrestrial CPR [48]. CPR in hypogravity is also found to be more tiring than CPR on Earth, however, not to the same degree as in microgravity [47].

Current ERC guidelines recommend rotating rescuers every 2 min to prevent a drop in quality of chest compressions. A similar or possibly shorter window, such as 90 s, would be recommended for CPR in hypogravity. For microgravity, if enough crewmembers are present, an even shorter window for rotating is recommended, such as 60 s, to preserve the quality of chest compressions.

It is also important to consider that microgravity is a novel environment in itself and can be disorientating, which could be a potential hazard in an emergency scenario. The internal environment of a spacecraft or the ISS is also small, with confined spaces that can limit the ability of the rescuer and patient to manoeuvre and transfer during CPR or any emergency. Specifically for the HS method, particular consideration must be given to placement of the patient and positioning of the rescuer's feet, as lots of equipment are found within the capsule and there is the potential for damage to be caused to walls or partitions if they are not strong enough to withstand the force applied for performance of the CPR chest compressions. For the RBH and ER methods, there is always the danger of floating and hitting the sides of the internal environment of the capsule/spacecraft when performing CPR.

The use of an AED also imposes risks. Its use must be controlled and applied only by those trained to handle the equipment. Evidence shows that there have been few injuries due to poor AED use; however, the isolated and unique environment of microgravity in particular

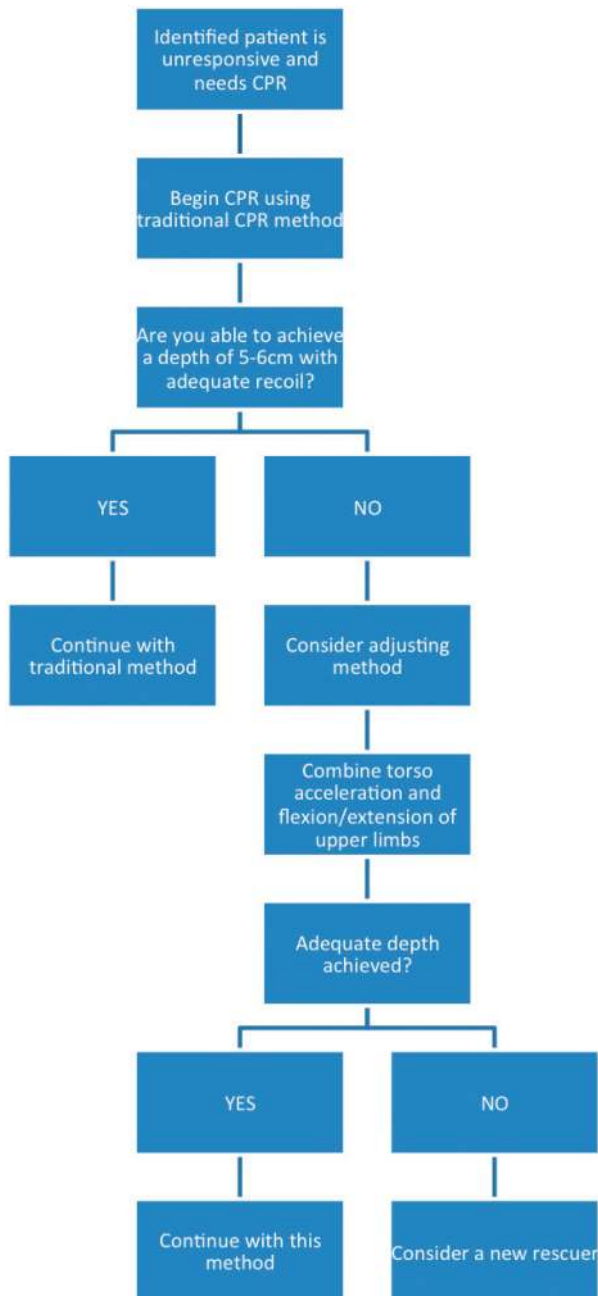

Figure 15. Algorithm for CPR in hypogravity.

can provide additional challenges in terms of making sure that rescuers are safe and clear when an AED is discharged.

## 7. Conclusion: extraterrestrial CPR—applications in space and on earth

As the space tourism industry commences and looks to expand over the following years, greater numbers of individuals will undertake suborbital flights and enter the microgravity environment. Before space tourism becomes a viable industry with regular flights, its technology will be tried and tested to the highest standards. The rapid rise in numbers of people who enter microgravity will pose a potentially significant increase in health problems, many of which participants will be unaware. Growing numbers of individuals will enter the space environment who will not have been subject to a strict preselection screening, such as that undergone by people preparing to join the astronaut corp [54]. This scenario could lead to potential difficulties: individuals will be at greater risk of a life-threatening cardiac event if they have not been screened for such health issues beforehand, and/or the physiological stress of launching and remaining in microgravity could exacerbate any underlying cardiovascular condition. This scenario could be further compounded by a shortage of individuals who have undertaken emergency training. This is a similar problem to that faced on Earth, with a varying uptake of BLS/CPR training across countries. However, the novelty factor of the microgravity environment combined with a serious medical emergency could create a highly stressful situation in which these bystanders are likely to be ill prepared and lacking the appropriate training necessary to carry out CPR techniques for the performance of adequate BLS. To this end, it is recommended that such individuals undergo appropriate training prior to a flight that would take them into an altered gravity environment. Healthcare professionals, schoolteachers and other civil servants who work with the public are currently given first aid and CPR training, and this exposure to basic BLS and CPR methods should be extended to all travellers into space. It is unrealistic to expect these individuals to be fully trained in all methods prior to launch, but familiarity with all methods, in accordance with ERC/AHA guidelines for CPR depth and rate of chest compressions, could better prepare them for the possibility of a serious cardiac event occurring that requires CPR.

Individuals who do find themselves in a situation of needing to administer BLS/CPR should initially follow the steps in **Figure 14**, making sure that a crewmember or ground control is aware that there is a medical emergency in progress. When commencing CPR, laypersons familiar with all three methods should be encouraged to perform the technique with which they feel the most comfortable and are consequently better able to deliver effective external chest compressions. As with the ERC/AHA guidelines, effective chest compressions should be favoured over ventilations.

Training and familiarisation with the novel CPR methods used in microgravity can enable laypersons to provide chest compressions and therefore maintain cardiac output and organ perfusion, until either a more qualified crewmember can takeover the procedure or until the craft ends its suborbital trajectory and returns to a normal gravitational environment where terrestrial CPR can commence. These steps will improve the chances of the patient having a favourable outcome.

Research into terrestrial CPR has shown that height and weight of the rescuer are correlated to effectiveness of chest compressions, and therefore, extraterrestrial CPR research could be used to improve terrestrial CPR, especially when physical disparities are encountered, such as when a rescuer is of smaller stature or lacks sufficient upper body weight. Examples of these scenarios include a child attempting to resuscitate an adult outside of a hospital situation or a small nurse resuscitating a large adult in hospital, who may also be obese or have significant lung pathology, such as pulmonary fibrosis or chronic obstructive pulmonary diseases, thus restricting further compliance of the chest.

Using the traditional straight-arm CPR technique, there reaches a point of critical mass when a rescuer is unable to overcome the resistance of the patient's chest to achieve the required 50–60 mm depth of chest compression. Without sufficient depth, not enough of a pressure gradient is created to circulate blood and perfuse organs. In these scenarios, the authors suggest a footnote to the CPR guidelines, concluding that extension of the upper limbs (triceps extension) can help augment the traditional straight-arm method with a synergistic acceleration of the body and extension of upper body to generate the force required to compress the chest.

## Author details

Thais Russomano<sup>1,2,3,4\*</sup> and Lucas Rehnberg<sup>1,5</sup>

\*Address all correspondence to: [thais.russomano@innovaspace.org](mailto:thais.russomano@innovaspace.org)

1 Centre of Human and Aerospace Physiological Sciences, Faculty of Life Sciences & Medicine, King's College, London, UK

2 International Space Medicine Consortium Inc., Washington, DC, USA

3 InnoVaSpace Consultancy, London, UK

4 Human Spaceflight Capitalisation Office, Harwell, UK

5 University Hospital Southampton NHS Foundation Trust, UK

## References

- [1] Eisenberg MS, Horwood BT, Cummins RO, Reynolds-Haertle R, Hearne TR. Cardiac arrest and resuscitation: A tale of 29 cities. *Annals of Emergency Medicine*. 1990;**19**:179-186. DOI: 10.1016/S0196-0644(05)81805-0
- [2] Baskett PJF. Peter Safar, the early years 1924-1961, the birth of CPR. *Resuscitation*. 2001;**50**:17-22. DOI: 10.1016/S0300-9572(01)00391-4
- [3] Travers AH, Perkins GD, Berg RA, Castren M, Considine J, Escalante R, Gazmuri RJ, Koster RW, Lim SH, Nation KJ, Olasveengen TM, Sakamoto T, Sayre MR, Sierra A, Smyth MA, Stanton D, Vaillancourt C. Basic Life Support Chapter Collaborators. Part 3: Adult basic life support and automated external defibrillation: 2015 international

- consensus on cardiopulmonary resuscitation and emergency cardiovascular care science with treatment recommendations. *Circulation*. 2015;**132**(16 Suppl 1):S51-S83. DOI: 10.1161/CIR.0000000000000272
- [4] Jay GD, Lee P, Goldsmith H, Battat J, Maurer J, Suner S. CPR effectiveness in microgravity: Comparison of three positions and a mechanical device. *Aviation, Space, and Environmental Medicine*. 2003;**74**:1183-1189
- [5] Rehnberg L, Russomano T, Falcão F, Campos F, Evetts SN. Evaluation of a novel basic life support method in simulated microgravity. *Aviation, Space, and Environmental Medicine*. 2011;**82**:104-110. DOI: 10.3357/ASEM.2856.2011
- [6] Krygiel RG, Wayne AB, Baptista RR, Heidner GS, Rehnberg L, Russomano T. The evaluation of upper body muscle activity during the performance of external chest compressions in simulated hypogravity. *Life Sciences in Space Research (Amsterdam)*. 2014;**1**:60-66. DOI: 10.1016/j.lssr.2014.01.004
- [7] Gell CF. Table of equivalents for acceleration terminology. *Aviation Medicine*. 1961; **32**:1109-1111
- [8] Rainford DJ, Gradwell DP. *Ernsting's Aviation Medicine*. 4th ed. London: CRC Press; 2006. p. 800. DOI: 10.1201/b13238
- [9] Barratt MR, Pool S. *Principles of Clinical Medicine for Space Flight*. 1st ed. New York: Springer; 2008. p. 596. DOI: 10.1007/978-0-387-68164-1
- [10] Alfrey CP. Effect of microgravity on the production of red blood cells. In: *Research in the Microgravity Environment Related to Cardiovascular, Pulmonary, and Blood Functions and Diseases*. Bethesda, MD: National Heart, Lung and Blood Institute and National Aeronautics and Space Administration Workshop; 20-21 January 1994. pp. 95-97
- [11] Alfrey CP, Udden MM, Leach-Huntoon C, Driscoll T and Pickett MH. Control of red blood cell mass in spaceflight. *Journal of Applied Physiology*. 1996;**81**:98-104
- [12] Riley DA, Ilyina-Kakueva EI, Ellis S, Bain JLW, Slocum GR, Sedlak FR. Skeletal muscle fiber, nerve, and blood vessel breakdown in space-flown rats. *The FASEB Journal*. 1990;**4**:84-91
- [13] Riley DA, Ellis S, Giometti CS, Hoh JFY, Ilyina-Kakueva EI, Oganov V, Slocum GR, Bain JLW, Sedlak FR. Muscle sarcomere lesions and thrombosis after spaceflight and suspension unloading. *Journal of Applied Physiology*. 1992;**73**(2):33S-43S
- [14] Oman CM, Lichtenberg BK, Money KE, McCoy RK. MIT/Canadian vestibular experiments on the Spacelab-1 Mission: 4. Space motion sickness: Symptoms, stimuli, and predictability. *Experimental Brain Research*. 1986;**64**(2):316-334. DOI: 10.1007/BF00237749

- [15] Moore AD, Lee SMC, Stenger MB, Platts SH. Cardiovascular exercise in the U.S. space program: Past, present and future. *Acta Astronautica*. 2010;**66**(7-8):974-988. DOI: 10.1016/j.actaastro.2009.10.009
- [16] Thornton WE, Hoffler GW, Rummel JA. Anthropometric changes and fluid shifts. In: Johnston RS, Dietlein LF, editors. *Biomedical Results from Skylab*. Washington, DC: NASA; 1977. pp. 330-338. (NASA Spec. Rep. SP-377)
- [17] West JB. Historical perspectives: Physiology in microgravity. *Journal of Applied Physiology*. 2000;**89**:379-384
- [18] Blomqvist CG, Stone HL. Cardiovascular adjustments to gravitational stress. In: Shepherd JT, Abboud FM, editors. *Handbook of Physiology, Section 2: The Cardiovascular System, Vol III, Peripheral Circulation and Organ Blood Flow*. Bethesda: American Physiological Society; 1983. pp. 1025-1063. DOI: 10.1002/cphy.cp020328
- [19] Johnson PC, Driscoll TB, LeBlanc AD. Blood volume changes. In: Johnson RS, Dietlein LF, editors. *Biomedical Results from Skylab*. Washington, DC: NASA; 1977. pp. 235-241
- [20] Fritsch-Yelle JM, Charles J, Jones MM, Wood ML. Microgravity decreases heart rate and arterial pressure in humans. *Journal of Applied Physiology*. 1996;**80**:910-914
- [21] Charles JB, Lathers CM. Cardiovascular adaptation to space flight. *The Journal of Clinical Pharmacology*. 1991;**31**(10):1010-1023. DOI: 10.1002/j.1552-4604.1991.tb03665.x
- [22] Shykoff BE, Farhi LE, Olszowka AJ, Pendergast DR, Rokitka MA, Eisenhardt CG, Morin RA. Cardiovascular response to submaximal exercise in sustained microgravity. *Journal of Applied Physiology*. 1996;**81**:26-32
- [23] Levine BD, Lane LD, Watenpaugh DE, Gaffney FA, Buckley JC, Blomqvist CG. Maximal exercise performance after adaptation to microgravity. *Journal of Applied Physiology*. 1996;**81**:686-694
- [24] Mader TH, Gibson CR, Pass AF, Kramer LA, Lee AG, Fogarty J, Tarver WJ, Dervay JP, Hamilton DR, Sargsyan A, Phillips JL, Tran D, Lipsky W, Choi J, Stern C, Kuyumjian R, Polk JD. Optic disc edema, globe flattening, choroidal folds, and hyperopic shifts observed in astronauts after long-duration space flight. *Ophthalmology*. 2011;**118**(10):2058-2069. DOI: 10.1016/j.ophtha.2011.06.021
- [25] Alexander DJ, Gibson CR, Hamilton DR, Lee SMC, Mader TH, Otto C, Oubre CM, Pass AF, Platts SH, Scott JM, Smith SM, Stenger MB, Westby CM, Zanello SB. *NASA Evidence Report: Risk of Spaceflight-Induced Intracranial Hypertension and Vision Alterations*. 2012. Available from: <http://humanresearchroadmap.nasa.gov/Evidence/reports/VIIP.pdf> [Accessed: 14-03-2017]
- [26] Johnston SL, Marshburn TH, Lindgren K. Predicted incidence of evacuation-level illness/injury during space station operation. Presented at the 71st Annual Scientific Meeting of the Aerospace Medical Association. Houston, Texas; 2000

- [27] Calder A, Nijar J, Scarpa P. Use of ultrasound for diagnosis in microgravity: Comparative survey of NASA flight surgeon and consultant radiologist opinions. *Aviation, Space and Environmental Medicine*. 2007;**78**(3). p.134
- [28] D'Aunno DS, Dougherty AH, DeBlock HF, Meck JV. Effect of short- and long-duration spaceflight on QTc intervals in healthy astronauts. *American Journal of Cardiology*. 2003;**91**:494-497. DOI: 10.1016/S0002-9149(02)03259-9
- [29] Platts SH, Stenger MB, Phillips TR, Arzeno NM, Brown AK, Levin B, Summers R. NASA publication. Evidence based review: Risk of cardiac rhythm problems during space flight. 2010. Available from: <https://ntrs.nasa.gov/archive/nasa/casi.ntrs.nasa.gov/20100017571.pdf> [Accessed 14-03-2017]
- [30] Fritsch-Yelle JM, Leuenberger UA, D'Aunno DS, Rossum AC, Brown TE, Wood ML, et al. An episode of ventricular tachycardia during long-duration spaceflight. *American Journal of Cardiology*. 1998;**81**:1391-1392. DOI: 10.1016/S0002-9149(98)00179-9
- [31] Perhonen MA, Franco F, Lane LD, Buckey JC, Blomqvist CG, Zerwekh JE, Peshock RM, Weatherall PT, Levine BD. Cardiac atrophy after bed rest and spaceflight. *Journal of Applied Physiology*. 2001;**91**(2):645-653
- [32] Huikuri HV, PekkaRaatikainen MJ, Moersch-Joergensen R, Hartikainen J, Virtanen V, Boland J, Anttonen O, Hoest N, Boersma LVA, Platou ES, Messier MD, Bloch-Thomsen P. Prediction of fatal or near-fatal cardiac arrhythmia events in patients with depressed left ventricular function after an acute myocardial infarction. *European Heart Journal*. 2009;**30**:689-698. DOI: 10.1093/eurheartj/ehn537
- [33] Prisk GK. Microgravity. American Physiological Society. *Comprehensive Physiology*. 2011;**1**:485-497. DOI: 10.1002/cphy.c100014
- [34] Paiva M, Verbanck S, Estenne M. Chest wall mechanics in microgravity: Results from parabolic flights. In: *Proceedings of the 5th European Symposium On Life Sciences Research in Space; August 2003*. ESA SP-336
- [35] Elliot AR, Prisk GK, Guy HJB, West JB. Lung volumes during sustained microgravity on Spacelab SLS-1. *Journal of Applied Physiology*. 1994;**77**:2005-2014
- [36] Prisk GK, Guy HJB, Elliot AR, West JB. Inhomogeneity of pulmonary perfusion during sustained microgravity on SLS-1. *Journal of Applied Physiology*. 1994;**76**(4):1730-1738
- [37] Guy HJB, Prisk GK, Elliot AR, Deutschmann III RA, West JB. Inhomogeneity of pulmonary ventilation during sustained microgravity as determined by single-breath wash-out. *Journal of Applied Physiology*. 1994;**76**(4):1719-1729
- [38] Vaida P, Kays C, Techoueyeres P, Lachaud JL, Riviere D. Pulmonary diffusing capacity and pulmonary capillary blood volume during parabolic flights. *Aviation, Space, and Environmental Medicine*. 1996;**67**:700 (Abstract 210)



- [39] Prisk GK, Guy HJB, Elliot AR, Deutschmann III RA, West JB. Pulmonary diffusing capacity, capillary blood volume, and cardiac output during sustained microgravity on SLS-1. *Journal of Applied Physiology*. 1993;**75**(1):15-26
- [40] Russomano T, Evetts SN, Castro J, dos Santos MA, Gavillon J, Azevedo DFG, Whittle J, Coats E, Ernsting J. A device for sampling arterialized earlobe blood in austere environments. *Aviation, Space, and Environmental Medicine*. 2006;**77**(4):453-455
- [41] Hamilton DR. Personal communication 9 Sept 2004 - Current ISS Cardiac Arrest Procedures; 2004
- [42] Evetts SN, Evetts LM, Russomano T, Castro JC, Ernsting J. Basic life support in microgravity: Evaluation of a novel method during parabolic flight. *Aviation, Space, and Environmental Medicine*. 2005;**76**:506-510
- [43] Johnston SL, Campbell MR, Billica RD, Gilmore SM. Cardiopulmonary resuscitation in microgravity: Efficacy in the swine during parabolic flight. *Aviation, Space, and Environmental Medicine*. 2004;**75**:546
- [44] Kordi M, Kluge N, Kloeckner M, Russomano T. Gender influence on the performance of chest compressions in simulated hypogravity and microgravity. *Aviation, Space, and Environmental Medicine*. 2012;**83**(7):643-648. DOI: 10.3357/ASEM.3171.2012
- [45] Rehnberg L, Baers JH, Velho R, Cardoso RB, Ashcroft A, Baptista R, Russomano T. The pathway to new guidelines what can CPR in simulated hypogravity teach us about CPR on Earth? In: *Proceedings of the European Resuscitation Council: Resuscitation 2014; 15-17 May 2014; Bilbao, Spain*. Resuscitation; 2014. 85:S6
- [46] Dalmarco G, Russomano T, Calder A, Falcao F, de Azevedo DFG, Sarkar S, Evetts S, Moniz S. Evaluation of external cardiac massage performance during hypogravity simulation. In: Wickramasinghe N, Geisler E, editors. *Encyclopedia of Healthcare Information Systems*. 1st ed. NY, USA: Medical Information science reference; 2008. Chapter E. pp. 551-560. DOI: 10.4018/978-1-59904-889-5.ch070
- [47] Russomano T, Baers JH, Velho R, Cardoso RB, Ashcroft A, Rehnberg L, Gehrke RD, Dias MK, Baptista RR. A comparison between the 2010 and 2005 basic life support guidelines during simulated hypogravity and microgravity. *Extreme Physiology and Medicine*. 2013;**2**(1):11. DOI: 10.1186/2046-7648-2-11
- [48] Rehnberg L, Ashcroft A, Baers JH, Campos F, Cardoso RB, Velho R, Gehrke RD, Dias MK, Baptista RR, Russomano T. Three methods of manual external chest compressions during microgravity simulation. *Aviation, Space, and Environmental Medicine*. 2014;**85**(7):687-693. DOI: 10.3357/ASEM.3854.2014
- [49] Benyoucef Y, Keady T, Marwaha N. The seated arm-lock method: A new concept of basic life support in simulated hypogravity of the moon and mars. *Journal of Space Safety Engineering*. 2014;**1**(1):28-31. DOI: 10.1016/S2468-8967(16)30069-6

- [50] Baers JH, Velho R, Ashcroft A, Rehnberg L, Baptista R, Russomano, T. Is weight a pivotal factor for the performance of external chest compressions on earth and in space? *Journal of Exercise Physiology Online*. 2016;**19**:1-15
- [51] Waye A, Russomano T, Krygiel R, Susin TB, Baptista R, Rehnberg L, Heidner G, Campos F, Falcao, F. Evaluation of upper body muscle activity during cardiopulmonary resuscitation performance in simulated microgravity. *Advances in Space Research*. 2013;**52**:971-978. DOI: 10.1016/j.asr.2013.05.028
- [52] Baptista RR, Susin TB, Dias MKP, Correa NK, Cardoso RB, Russomano T. Muscle activity during the performance of CPR in simulated microgravity and hypogravity. *American Journal of Medical and Biological Research*. 2015;**3**:82-87. DOI: 10.12691/ajmbr-3-4-1
- [53] Hupfl M, Selig HF, Nagele P. Chest-compression-only versus standard cardiopulmonary resuscitation: A meta-analysis. *Lancet*. 2010;**376**(9752):1552-1557. DOI: 10.1016/S0140-6736(10)61454-7
- [54] Rayman RB, Antuñano MJ, Garber MA, Hastings JD, Illig PA, Jordan JL, Landry RF, McMeekin RR, Northrup SE, Ruelle C, Saenger A, Schneider VS. Space passenger task force. Medical guidelines for space passengers. *Aviation, Space, and Environmental Medicine*. 2002;**73**(11):1132-1134