

Chapter

Gyrotron: The Most Suitable Millimeter-Wave Source for Heating of Plasma in Tokamak

Santanu Karmakar and Jagadish C. Mudiganti

Abstract

In this chapter, brief outline is presented about gyro-devices. Gyro-devices comprise of a family of microwave devices and gyrotron is one among those. Various gyro devices, namely, gyrotron, gyro-klystron and gyro traveling-wave tubes (gyro-TWT) are discussed. Gyrotron is the only microwave source which can generate megawatt range of power at millimeter-wave and sub-millimeter-wave frequency. Gyrotron is the most suitable millimeter wave source for the heating of plasma in the Tokamak for the controlled thermoneuclear fusion reactors. This device is used both for the electron cyclotron resonance heating (ECRH) as well as for the electron cyclotron current drive (ECCD). In this chapter, the basic theory of gyrotron operation are presented with the explanation of various sub-systems of gyrotron. The applications of gyrotrons are also discussed. Also, the present state-of-the-art worldwide scenario of gyrotrons suitable for plasma heating applications are presented in details.

Keywords: gyrotron, electron cyclotron resonance heating, fast wave device, gyrotron cavity

1. Introduction

The conventional microwave-tubes, such as traveling-wave tubes (TWSs) and klystrons follow the Pf^2 law. As per this law, the product of maximum power (P) and the square of frequency (f^2) is constant for a device. This limits the maximum power handling capability of a device at higher frequency, i.e., in the millimeter-wave and sub-millimeter-wave frequency regime. Hence, it was found to be highly difficult to develop a microwave source, capable of delivering megawatts of power at millimeter wave frequency. In the last few decades, a new class of microwave tube has emerged, called – Gyrotrons [1–9], which are based on cyclotron resonance maser (CRM) instability [10–12]. This class of device has the capability to produce very high power at millimeter-wave frequencies, much higher than other microwave devices.

The gyrotron is the most suitable source for the heating of plasma in Tokamak for controlled thermoneuclear fusion reactors. Gyrotron is being used as the heating source for electron cyclotron resonance heating (ECRH) as well as for the electron cyclotron current drive (ECCD).

Gyro-devices comprise of a family of microwave devices and gyrotron is one among those. However, gyrotron being the most popular gyro-device, the entire gyro-device family is sometime referred as gyrotrons. Various other commercially available gyro-devices are: gyro-klystron, gyro-traveling wave tubes (gyro-TWT) and gyro-twistron (a combination of Gyro-TWT and Gyro-Klystron).

In a gyro-device, a hollow electron-beam is generated with the help of a special kind of electron gun, known as magnetron injection gun (MIG) operating in temperature-limited regime of thermionic emission. This hollow electron beam is made to gyrate at cyclotron frequency with the help of a strong axial magnetic field. Subsequently, this gyrating electron beam is passed through an interaction structure, where the electron-beam interacts with the electromagnetic-wave (EM-wave). In case of gyrotron, the interaction-structure is an open-ended cavity. In case of gyro-TWT, the interaction structure is waveguide with an input and output coupler. When the cyclotron frequency synchronizes with the frequency of the EM-wave (frequency of EM-wave supported by the cavity in case of gyrotron and frequency of the EM-wave fed at the input coupler in case of gyro-TWT) the beam-wave interaction takes place. The transverse kinetic energy of the electron-beam gets converted to electromagnetic energy. Hence, the EM-wave gets generated (in gyrotron) or amplified (in gyro-TWT).

Let us now briefly discuss the origin of gyrotrons. It has been well known since the mid-fifties that there appeared to be a limit to the upper frequency at which most vacuum microwave devices could be made to operate with sufficient power and efficiency, primarily due to the reduction of physical size of the components of the device with increase of frequency [13]. This problem can be explained as follows: As the frequency of operation of the device increases, the dimension of the waveguide or cavity or the loading elements inside the waveguide (such as helix in case of helix-TWT) become uncomfortably small, as their physical size is closely related to the operating wavelength of the device. Furthermore, since the depth of penetration of the field generated by the electromagnetic wave is proportional to the operating wavelength, the field penetration inside the loading-element reduces with the increase of operating frequency. Hence, in order to have a proper interaction between the electron-beam and electromagnetic wave, electron-beam needs to be placed closer to the structure carrying electromagnetic wave, if we wish to retain an acceptable efficiency of beam-wave interaction [1, 2]. All these awkward requirements clearly indicate an urgent need for a radical change of approach. In conventional vacuum electronic slow-wave devices (such as TWT), periodic loading elements are required for slowing down the phase velocity of the electromagnetic wave (slow wave interaction: $v_{ph} < c$) so that the phase velocity becomes synchronized with the velocity of the slow space-charge wave produced by a perturbed electron beam. In case of helix-TWT, helix acts as periodic loading element, alternatively known as slow-wave structure (SWS). Whereas in gyro-device, alternatively known as fast-wave devices, the periodicity in the propagating medium is removed and the periodicity is brought in-to the electron-beam. The interaction now takes place with an electromagnetic wave whose phase velocity is higher than the free-space velocity of light (fast wave interaction, $v_{ph} > c$) [1–3]. Instead of periodicity of the loading element, the periodicity of the electron-beam comes into play. This leads to a quasi-synchronism between the electromagnetic wave and the electron-beam.

Gyro-devices comes under the category of Bremsstrahlung radiation device [13]. Here, instead of periodic slow-wave-structure, the electron beam is made periodic by generating a hollow electron-beam gyrating under the influence of a strong axial magnetic field. When this electron beam is perturbed, two cyclotron waves get generated, namely slow and fast cyclotron wave. When the velocity of the fast

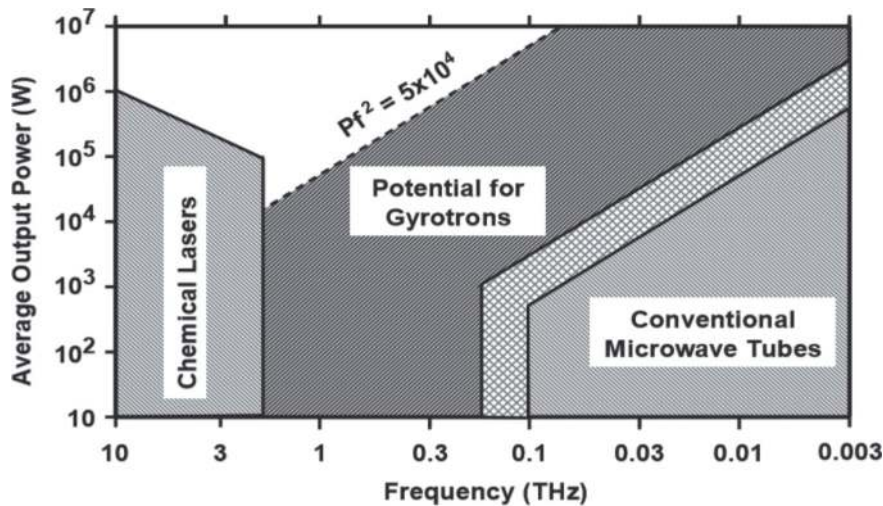

Figure 1.
 Domain of microwave tubes/ laser devices.

cyclotron wave is synchronized with EM-wave, beam-wave interaction takes place. That's why these devices are known as fast-wave device.

A variety of interaction structure geometries are proposed in the literature [9, 11–13] for gyro-devices. In case of gyrotron, the interaction structure is an open ended cavity. Well directed and concentrated efforts were made in the mid-seventies by Granstein and his team at the Naval Research Laboratory (NRL) [13], as well as Gapanov and his team at IAP, Russia [14] who, with some help from others, succeeded in mounting an extensive research effort in the whole area of Bremsstrahlung radiation device, which include free-electron lasers as well as gyrotrons. Since then, gyro-devices have developed very rapidly to offer prodigious amounts of power, and very high efficiency of the order of 50% or more. **Figure 1** shows capabilities of various vacuum electronic devices in terms of frequency and average power. It's evident from the figure, for frequencies above the Terahertz range, laser devices are most suitable source for generation of electromagnetic wave. Again, for frequencies below the millimeter-wave range, conventional microwave tubes are most suitable source for the generation of high power. Gyrotron fits in between these two frequency regimes. Gyrotrons are best suited when the operating wavelength is approximately 1 mm and output power requirement is between hundreds of kilowatts to few megawatts. That's why Gyrotron is found to be the most suitable source for the heating of plasma.

2. Basic types of gyro device

Ever since the advent of cyclotron-resonance maser (CRM) instability devices, a vast amount of research work has been carried out and a number of gyro-devices have been developed. Out of these, the most popular device is gyrotron (alternatively known as gyro-monotron). The other two commercially available gyro-devices widely used in radar applications are, gyro-TWT [3, 8], and gyro-klystron [3]. However, the entire class of gyro-devices are usually referred as gyrotron. There are few less popular gyro-devices, namely, Gyro backward-wave oscillator (gyro-BWO), gyro-twysteron [3] (a combination of gyro-TWT and gyro-klystron), cyclotron autoresonance maser (CARM) and slow-wave cyclotron amplifier (SWCA) [13]. Technology for these devices are not as matured as for gyrotron,

gyro-TWT and gyro-klystron. Some of the gyro-devices are oscillators and some are amplifiers. Same is brought out in the **Table 1**.

In **Table 1**, the most popular gyro-device names are written in red. As is evident from the **Table 1**, cyclotron autoresonance maser (CARM) can be configured both as amplifier as well as oscillator.

In the following section, two most popular gyro-devices, namely, gyrotron, and gyro-TWT are discussed in brief with the schematic diagrams.

2.1 Gyrotron (gyro-monotron)

A schematic diagram of the gyrotron with axial output of cavity mode is shown in **Figure 2(a)**. The schematic view of high-power gyrotron with radial output of Gaussian beam is shown in **Figure 2(b)**. Here the beam-wave interaction takes place in an open-ended cavity. The hollow electron-beam from the electron-gun (known as magnetron injection gun) is injected into a region with very strong axial magnetic field [3, 6–10]. Magnetic flux densities of the order of several Tesla are normally required and this usually necessitates the use of superconducting magnets [6].

The beam-wave interaction takes place in the interaction cavity region. In order to avoid the thermal issues, gyrotrons usually incorporate a highly overmoded cavity. The reported continuous wave (CW) and pulsed power capabilities of the gyrotron are three orders of magnitude higher than the conventional microwave oscillators.

In case of axial output gyrotrons (**Figure 2(a)**), output millimeter-wave generated in the cavity propagates along the axis of the gyrotron and comes out of the gyrotron through an output-window. The spent-electron beam (the electron-beam after the beam-wave interaction) gets collected in the collector. In case of gyrotron with radial-output (**Figure 2(b)**), the cavity-resonator mode of EM-wave gets converted to Gaussian (TEM₀₀) mode with the help of a quasi-optical launcher (QOL) and 3 or 4 mirrors. The Gaussian beam comes out of the gyrotron radially (perpendicular to the axis of gyrotron) through the output-window and the spent electron-beam gets collected in the collector.

2.2 Gyro-traveling wave tube (gyro-TWT)

Gyro-TWT is a high power millimeter-wave amplifier [3, 8]. This is used in millimeter-wave radars. Gyro-TWT is also used for electron-cyclotron current drive (ECCD) for Tokamak. In this device, the interaction-cavity is replaced by a non-resonant structure (waveguide) to produce beam-wave interaction. This device has the potential of amplifying EM-powers of 2 orders of magnitude higher than the

Oscillator	Amplifier
Gyrotron(Gyro-Monotron)	Gyro TWT
Gyro Backward Wave Oscillator	Gyro Klystron
Gyrotron	Gyro Twistron
CARM	Cyclotron Autoresonance Maser (CARM)
	Slow Wave Cyclotron Amplifier (SWCA)
	Gyrotron-TWT
	Magnicon

Table 1.
The complete family of gyro-device.

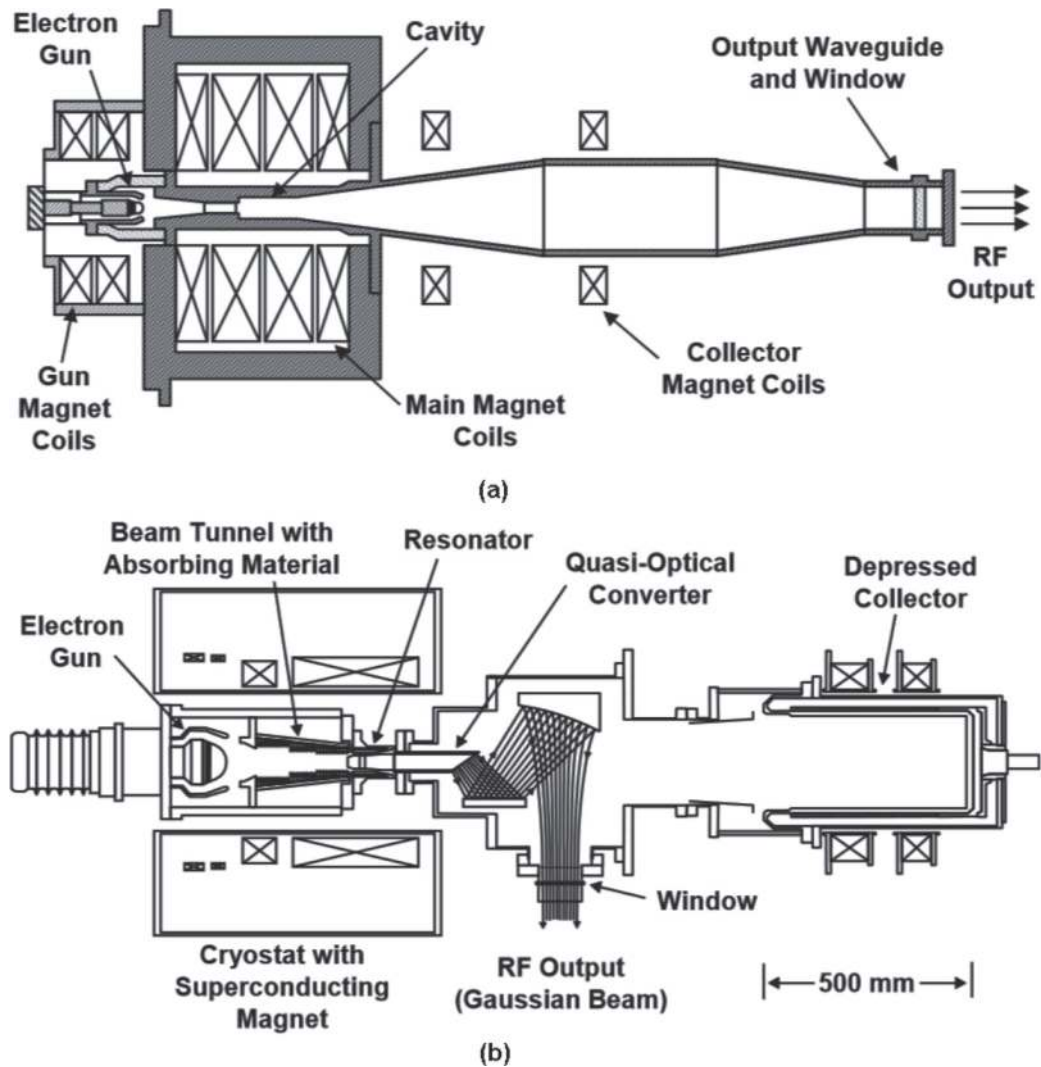

Figure 2.
 (a): Gyrotron with axial output. (b): High power Gyrotron with radial output of Gaussian beam.

conventional TWT. Gyro-TWT provides a high spectral quality amplification over a narrow bandwidth. The device interaction essentially involves a narrow band resonance between the electron-beam and the electromagnetic-wave near the waveguide cut-off due to the dispersive nature of the waveguide interaction structure. However, wideband coalescence is possible by proper dispersion shaping of the waveguide. Axial phase synchronism is required between the traveling wave and the gyrating electron. Techniques are being used to increase the band-width by

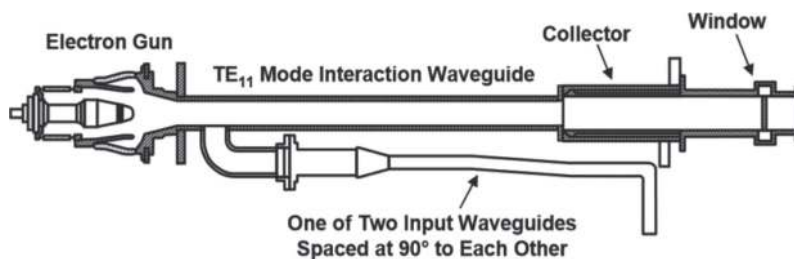

Figure 3.
 Gyro TWT.

tapering the magnetic field or by periodically loading the waveguide structure. The cross sectional view of gyro-TWT is shown in the **Figure 3**.

3. Basic principle of gyrotron

In a gyrotron, the electron beam, which is normally in the shape of a thin hollow cylinder, is injected into a region with strong axial magnetic field and passed through a cylindrical cavity or waveguide region containing an electromagnetic wave with an azimuthal component of electric field [1–3]. The rotational velocities of the electrons are normally 1.2 to 2 times the axial velocity. So, majority of the electron energy is rotational.

Because the magnetic field is very large, the orbit diameter for the electrons is very small. As a result, the thickness of the hollow electron beam is several times the diameter of the electron orbit as shown in **Figure 4**, and in effect, the hollow electron-beam contains a large number of small beams, referred as beamlets [2, 6]. **Figure 4** shows the thickness of the hollow electron-beam as twice the diameter of beamlet.

The basic operating mechanism of gyrotron can be explained by considering the interaction of a single beamlet of electrons with the electric field. In **Figure 5** it is assumed that electrons in a single beamlet are initially uniformly distributed along a single helical path prior to interaction with the RF electric field. The electrons are assumed to rotate in the counter clockwise direction as they move through the RF field. The rotational frequency of electrons is the cyclotron frequency, which is given by

$$\omega_c = \frac{e}{m} B_0 \quad (1)$$

Where, B_0 is the externally applied axial magnetic field, e is the electron-charge, and m is the mass of the electron. In a gyrotron, the velocity of electrons is a significant fraction of the free-space velocity of light, hence, the relativistic effect comes into play. So, the mass of the electrons is significantly greater than their rest-mass, i.e.,

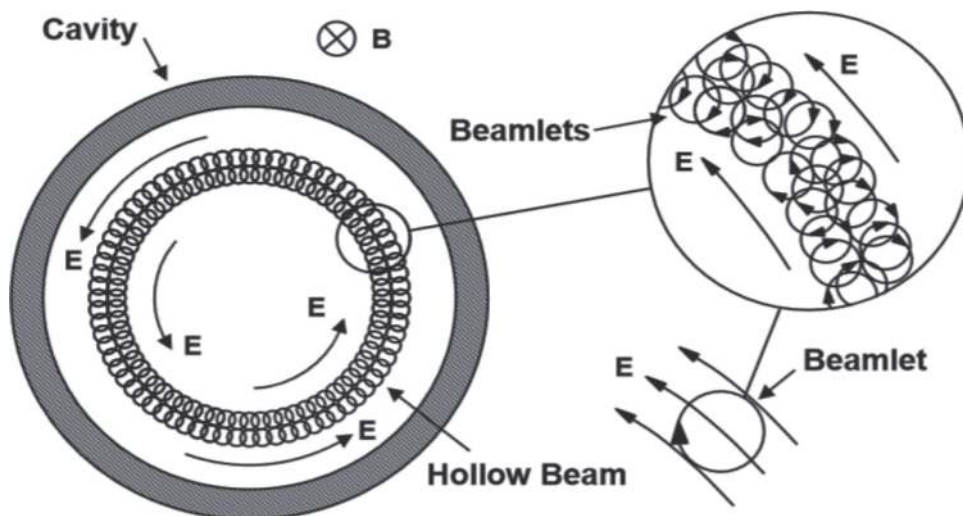

Figure 4.
Gyrotron cross section showing electron trajectories.

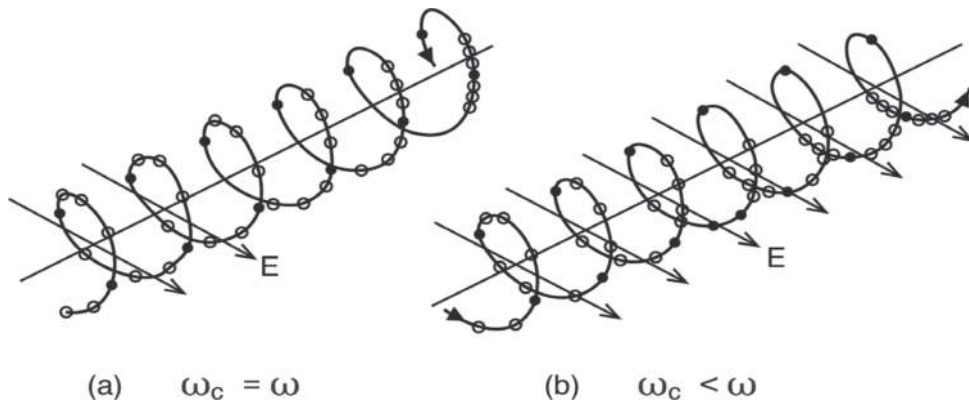

Figure 5.
 Bunching of electrons in a Gyrotron.

$$m = \gamma m_0 \quad (2)$$

Where m_0 is the rest-mass of the electron and γ is the relativistic mass factor, which is given by

$$\gamma = \frac{1}{\sqrt{1 - (v/c)^2}} \quad (3)$$

Where, v is the velocity of electron and c is the free space velocity of light. The value of γ increases when an electron is placed in an accelerating field.

The radius of the gyrating orbit, alternatively known as Larmor radius (r_L), may be obtained by the following equation

$$\omega_c r_L = v_t \quad (4)$$

Where, v_t is the transverse velocity of the electron-beam.

Now, referring again to **Figure 5(a)**, when the electric field is such that it tends to accelerate electrons (top of the orbits), the electron mass is increased and so the cyclotron frequency (ω_c) decreases for these electrons. Similarly, when the electric field tends to decelerate electrons (bottom of the orbits), the electron mass is decreased, and so ω_c is increased. Since the rate of rotation is decreased for some electrons and is increased for others, orbital bunching occurs if the electrons are permitted to drift, as indicated at the right-hand side of **Figure 5(a)**.

If the cyclotron frequency (ω_c) is somewhat lower than the frequency of the electromagnetic wave (ω), then the position of the bunches along the helical orbit is delayed with respect to the phase of the applied field as indicated in **Figure 5(b)**. Hence, the bunched electrons face a decelerating field and give-up their kinetic energy to the field. As the electron bunches rotate in near synchronism with the alternating RF-field, they continue to give-up energy on each half-cycle of rotation.

The interaction that has just been described for the electrons in a single beamlet in a gyrotron also takes place in the other beamlets. Thus, the electron distribution becomes as indicated in **Figure 6**. As the direction of the electric field alternates, the direction of motion of electron also alternates, and so the electrons throughout the transit period of the electron-beam give-up energy on each half cycle of operation. This is how the beam-wave interaction happens.

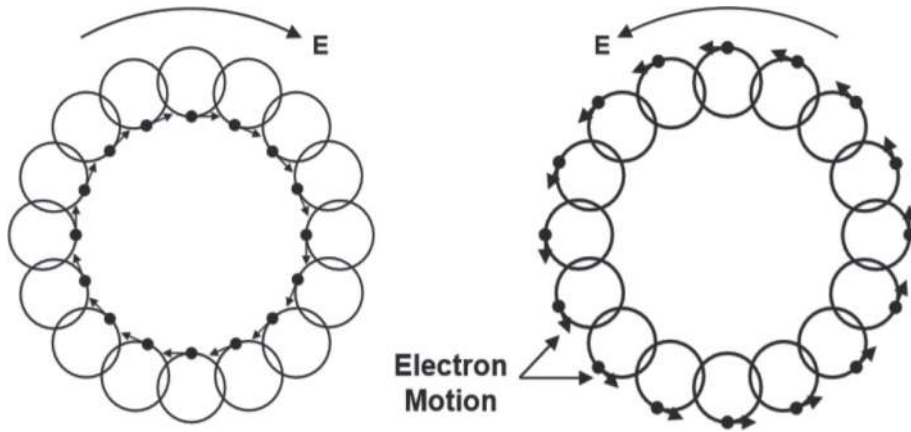

Figure 6.
Electron motion in relation to direction of electric field in a gyrotron.

3.1 Operation at harmonics of cyclotron frequency

With the proper shape of the RF-field, it is possible to excite harmonic mode of interactions with the electrons [1, 2, 8, 13–15]. As shown in **Figure 7**, the EM-wave field oscillates at a frequency twice the cyclotron frequency [2], i.e., $\omega = 2\omega_c$. The direction of the field reverses in the center of the electron orbit. Thus, an electron that is initially decelerated by the field is moving transverse to the field when the field reverses, and so does not have its orbital energy changed. By the time the field reverses again, the electron has moved 90° around its orbit and is again in a decelerating field. Thus, during each full orbital motion of electron, the RF-field goes through two complete cycles. Hence, for harmonic mode of operation, for a given operating frequency, the cyclotron frequency is half the value used in fundamental mode of operation. As a result, the magnetic field is reduced by a factor of two. Operation at frequencies higher than the second harmonic are also being examined [15], but the intensity of the interaction is reduced, making the efficiency of gyrotron low.

For harmonic mode operation, the frequency of operation of the gyrotron is approximately given by

$$\omega \cong s \left(\frac{e}{\gamma m_0} \right) B_0 \quad (5)$$

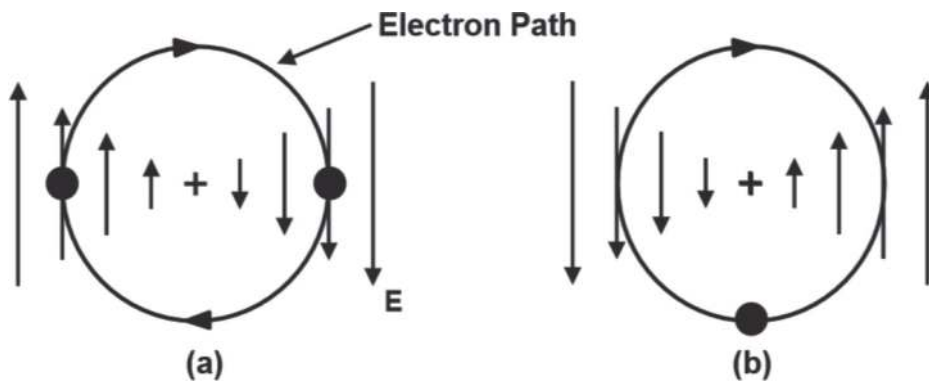

Figure 7.
Harmonic interaction of an electron and a field varying at twice the cyclotron frequency. (a) At an arbitrary time T , (b) At half RF cycle after T .

where, s is an integer, representing the harmonic number. Value of s equals to 2 corresponds to second harmonic operation. It signifies that the electromagnetic-wave frequency of the gyrotron is chosen to be twice the cyclotron frequency. Harmonic operation reduces the magnetic field requirements by factor of s (B_0/s). For gyrotrons operating at W-band or above, magnetic field requirement is very high (beyond 3 Tesla), it's not possible to obtain such magnetic field from a normal solenoid magnet. This necessitates the use of superconducting-magnets. Harmonic operation is a suitable choice for such class of gyrotrons, as second harmonic operation reduces the magnetic field requirement to half. Hence, such magnets can be built with non-superconducting solenoid coils. However, the harmonic operation reduces the efficiency of the gyrotron.

4. Main subsystems of gyrotron

In a gyrotron, a hollow electron beam gyrating at cyclotron frequency under the influence of a strong axial magnetic field interacts with the transverse electric field excited inside the cavity. If the cyclotron frequency is synchronized with the frequency of millimeter wave supported by the cavity (cut-off frequency of the cavity) for the selected higher order mode, millimeter wave gets generated. This phenomenon is known as cyclotron resonance maser (CRM) interaction. The hollow gyrating electron-beam is generated with the help of magnetron injection gun (MIG). The gyrating electron-beam is passed through a beam-tunnel and fed into an open ended interaction-cavity. The millimeter wave generated in the cavity region diffracts out with the help of a non-linear taper (NLT). The waveguide mode of electromagnetic-wave is covered to Gaussian mode with the help of a quasi-optical launcher (QOL) and mirror units. The millimeter wave is taken out of the gyrotron with the help of a high power millimeter-wave window. The spent electron-beam is collected in a collector. The required axial magnetic field throughout the gyrotron, starting from the MIG to collector is provided by a magnetic-system consisting of a main superconducting-magnet along with a number of non-superconducting solenoid magnets. Out of all these subsystems, MIG and interaction-cavity are the most important subsystems of gyrotron. The following section describes some of these main subsystems of gyrotron.

4.1 Magnetron injection gun (MIG)

Most high power gyrotrons use magnetron injection guns (MIGs), which produce annular electron-beams in which electrons gyrate in cyclotron frequency. The gyrating frequency is so chosen that the beam-wave interaction at desired mode can take place. For good interaction-efficiency, the transverse velocity component of electron should be as large as possible. A spread in transverse velocity results in a spread in axial velocity, and eventually reduces the efficiency of the gyrotron. Hence, the electron velocity spread should be kept as small as possible [8]. The cut-section view of a typical MIG with anode is shown in **Figure 8** indicating various parts of MIG.

The electrons are emitted from an annular cathode operating in temperature limiting regime of thermionic emission [2, 3]. MM-type dispenser cathode is used as emitter. The electron motion is taking place in crossed electric and magnetic fields so that the electrons follow helical trajectories around the magnetic flux lines with the electrons gyrating in cyclotron frequency. The accelerating potential of 20–70 kV is applied between the cathode and the anode. The MIG can have a diode or a triode configuration. In the triode configuration, there are two anodes, namely

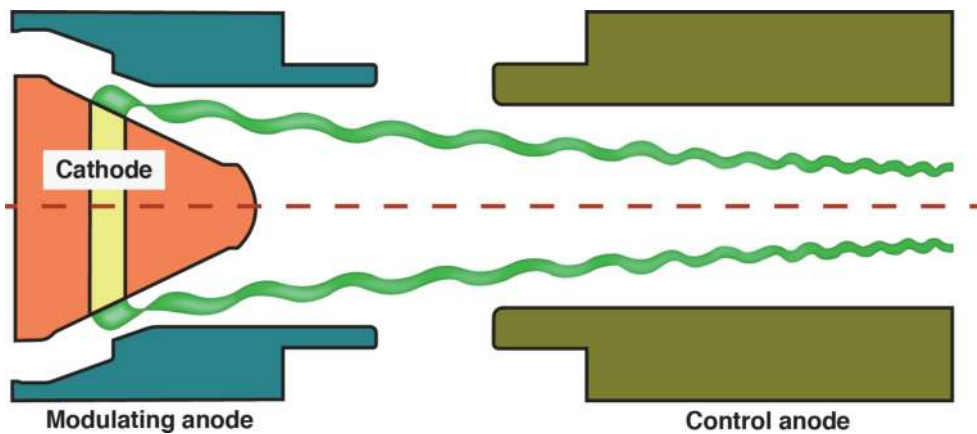

Figure 8.
Cut-section view of a typical MIG.

modulating anode and accelerating anode. In triode configuration, second anode provides the main accelerating potential. Whereas, the first anode (which is closer to cathode) is used to fine-tune the velocity pitch-factor of the beam (ratio of transverse to axial beam-velocity) as well as for pulsing the beam (i.e., for switching the beam ON and OFF). Gyro-TWT's usually incorporate triode MIG. In diode configuration, there is only one anode. Diode MIG needs much simpler power-supply for providing the necessary voltages. However, on the flipside, gyrotrons with diode MIG have lesser control over the beam.

4.2 Interaction cavity and nonlinear taper

The gyrating electron beam enters the interaction cavity, where the beam-wave interaction takes place [3, 6, 8–13]. This is an open ended overmoded cavity operating near cut-off [3, 6]. The interaction cavity generally consist of 3 sections, namely downtaper-section, straight section and uptaper-section. The shape of the cavity is dependent on the mode of the electromagnetic field with which the beam is intended to interact and also the harmonic number of interaction. The required diffractive quality factor of the cavity is achieved by proper fine tuning of the cavity shape. Schematic drawings of a typical Gyrotron cavity is presented in **Figure 9**.

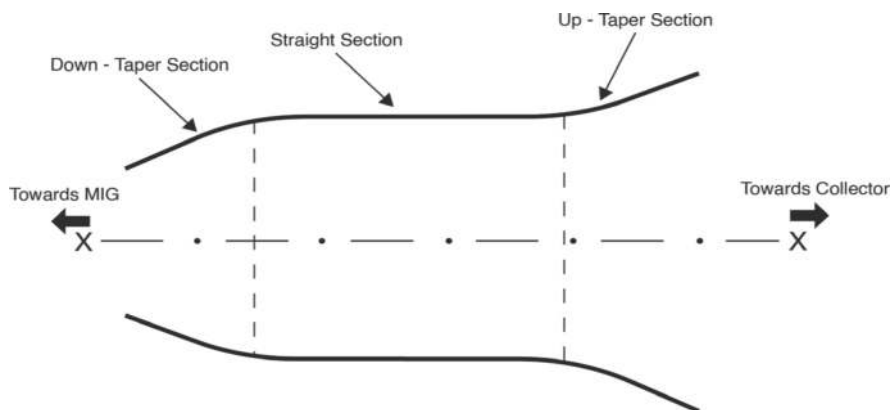

Figure 9.
A typical Gyrotron cavity.

The down-tapering is offered to the input-end of the cavity. This prevents the millimeter wave from back-traveling towards the MIG. The up-tapering is offered in the output-end of the cavity. The up-tapering helps the millimeter-wave to diffract out of the cavity. In case of coaxial gyrotrons, a coaxial insert is placed at the center of the cavity. The main beam-wave interaction takes place at the straight section of the cavity.

The millimeter-wave signal generated in the cavity needs to diffract out of the cavity. The same is achieved by the non-linear taper (NLT). This NLT is basically a tapered waveguide section with a specific tapering profile. A raised-cosine profile is incorporated in the NLT region to avoid reflection of electromagnetic-wave. This section acts as an interface between the interaction cavity and the QOL [6, 16–20]. Generally interaction cavity operates at a mode much higher than the dominant mode of the cavity. This enable the use of much higher cavity dimension and volume and this in-turn eliminates the bearing on the maximum power handling capacity at higher frequencies of millimeter-wave and sub-millimeter-wave regime. Broadly, the cavity operating modes are divided into three categories, namely, $TE_{0\ n}$ mode, $TE_{m\ n}$ ($m > n$) mode and $TE_{1\ n}$ mode. $TE_{m\ n}$ mode, when $m > n$, is called the whispering gallery mode. This mode is most widely used in gyrotrons for plasma heating applications. The relative merits and demerits of these modes are presented in the **Table 2**.

4.3 Beam-tunnel

The radius of the hollow electron beam generated by MIG is generally much larger than the required hollow beam radius at the cavity region. The purpose of the beam-tunnel is to gradually bring down the beam radius to the value needed in the cavity region. Beam-tunnel is basically a cylindrical waveguide structure placed between the anode and interaction-cavity. The inner radius of the beam-tunnel at the anode end is matched to the anode inner radius and at the cavity end is matched to the input inner radius of the cavity. In order to ensure that the beam-tunnel does not take part in interaction, lossy dielectric material is placed inside the beam-tunnel. One of the popular configuration of beam-tunnel is a stack of alternate metal (OFHC copper) and lossy ceramic (AlN, SiC) rings stacked inside the cylindrical waveguide of beam-tunnel (**Figure 10**). The axial length of the beam-tunnel is so chosen that that the electron beam undergoes an adiabatic compression as it propagates from the MIG to the cavity, i.e., the beam trajectories follows the magnetic flux lines. This configuration ensures maximum beam laminarity and minimum beam-turbulence. Cavity.

4.4 Quasi-optical launcher

The purpose of the quasi-optical launcher (QOL) is to convert the cavity mode of EM-wave into a Gaussian (TEM_{00}) mode. This is accomplished with the help of a helically-cut waveguide section (QOL) followed by 3 or 4 toroidal mirrors system. QOL consist of a mildly tapered waveguide structure with helically cut end (known as Vlasov launcher) with dimple patterned inner surface (Denisov type surface deformation). Millimeter wave is launched from the QOL to the mirror system [16]. After passing through the mirror system, a Gaussian beam (with more than 98% Gaussian mode purity) is emerged. A typical QOL and 3 mirrors for converting $cavity$ mode to Gaussian (TEM_{00}) mode is shown in **Figure 11**. The Gyrotron with Gaussian output is most suited for plasma heating applications. Because, the Gaussian

<p>TE_{0n} Mode</p> 	<p>Advantage</p> <ul style="list-style-type: none"> • Smallest Ohmic Loss • Easy to excite <p>Disadvantage</p> <ul style="list-style-type: none"> • Suffers from mode competition with TE_{2n} mode • Difficult to convert to Gaussian (TEM₀₀) mode
<p>Whispering Gallery Mode (TE_{m n}) m >> n</p> 	<p>Advantage</p> <ul style="list-style-type: none"> • Beam need to be placed near the cavity wall. Reduces space charge depression • Suitable for high harmonic operation (reduced magnetic field requirement) • Large Cavity dimension leads to high power handling capability <p>Disadvantage</p> <ul style="list-style-type: none"> • Prone to higher beam interception on the cavity wall
<p>TE_{1 n} mode</p> 	<p>Advantage</p> <ul style="list-style-type: none"> • Mode competition can be avoided by splitting the cavity wall • Beam need to be placed near the center of the cavity. Hence less beam interception on the cavity wall <p>Disadvantage</p> <ul style="list-style-type: none"> • Higher space-charge depression inside the cavity

Table 2.
Gyrottron cavity modes.

millimeter-wave beam can be transmitted through a waveguide over a very long distance with very little attenuation. Hence, the gyrotron can be placed away from the plasma vessel. Sometimes, the Gaussian beam is further converted to HE₁₁ mode with the help of a matching optic unit (MOU) placed external to gyrotron and then transmitted to the plasma vessel. This arrangement further reduces the attenuation of the beam.

4.5 High power output window

The millimeter-wave signal is finally taken out of the gyrotron with the help of the high-power output window. This window consists of a ceramic disc which isolates the ultra-high vacuum environment inside the gyrotron enclosure from the outside

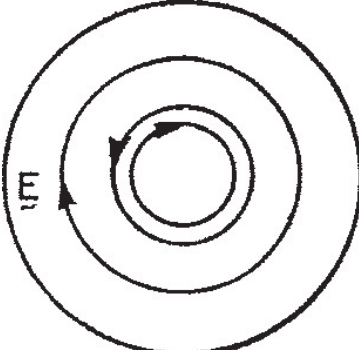
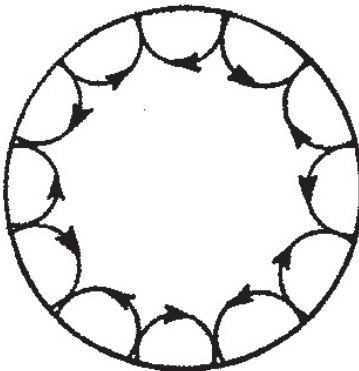
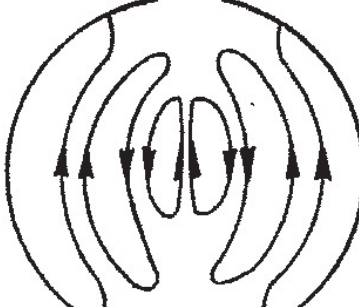
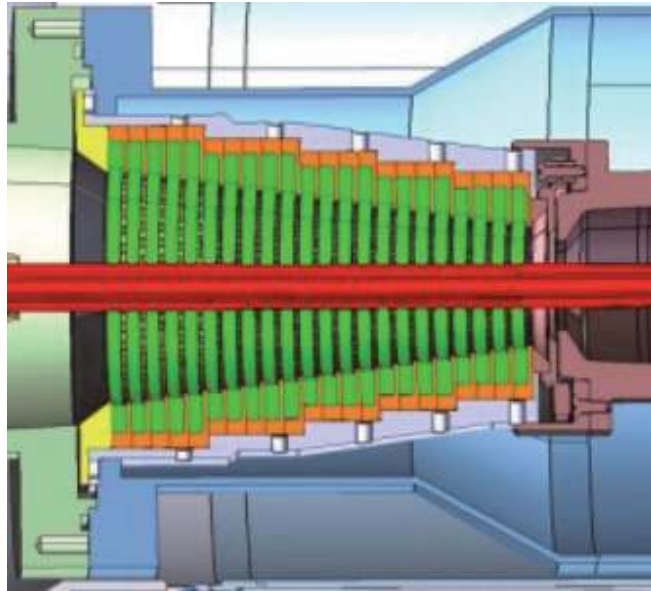

Figure 10.
Cut section view of a beam tunnel.

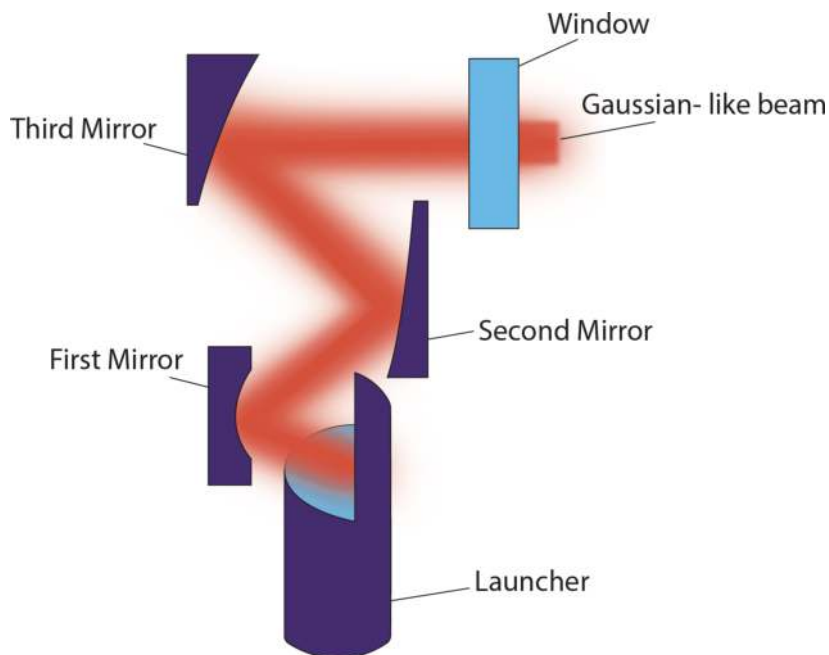

Figure 11.
A typical QOL for converting $TE_{6,2}$ cavity mode to Gaussian mode.

atmosphere. The ceramic disc material and thickness is so chosen that it appears almost transparent to the electromagnetic-wave and the millimeter-wave comes out of the gyrotron through the window with minimum attenuation. Also, a material, which is a good thermal conductor but bad electrical conductor, is chosen for window. Usually single disc window is used. However, for the purpose of VSWR matching, sometime double disc window may be incorporated. For short-pulse operation, sapphire, beryllium-oxide (BeO) or boron-nitride may be used as window ceramic materials. For long pulse high-power operation, chemical vapor deposition (CVD)

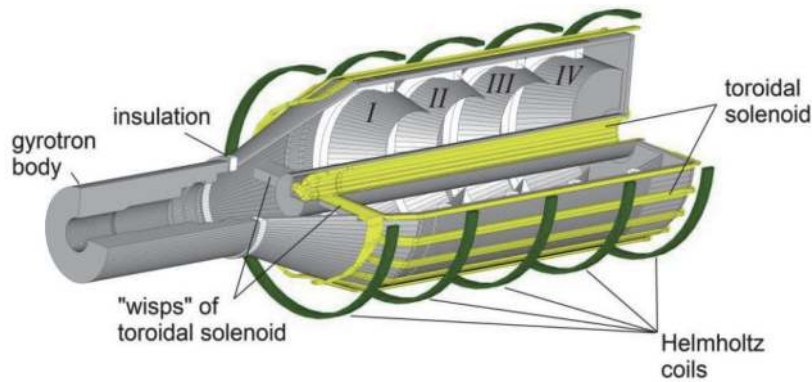

Figure 12.
Cut-section view of a typical collector.

diamond is generally used as the window material due to its very high thermal conductivity.

4.6 Collector

After the electron-beam comes out of the interaction-cavity, the spent electron-beam gets collected in the collector. The kinetic energy of the spent-electron beam (the electron-beam which has already undergone beam-wave interaction) gets dissipated in the collector. Hence, if the electronic-efficiency of a gyrotron is 40%, 60% of the electron beam power gets dissipated in the collector. Since the dissipated power in the collector is very high, the thermal management of collector is a very critical issue. The cut-section view of a typical collector is presented in the **Figure 12**. In some of the high power gyrotrons, a low frequency magnetic sweeping coil is used for sweeping the electron-beam along the length of collector to avoid creation of hot-spots. For the enhancement of overall efficiency of gyrotron, multi-stage depressed collector (MDC) is used, where the collector is kept at a negative potential with respect to cavity.

4.7 Magnetic system

The purpose of the magnetic system is to generate required axial magnetic field profile needed for the cavity as well as the MIG and collector. For lower frequency operation, non-superconducting air-cooled solenoids are preferred. However, for higher frequency operation (i.e., for gyrotrons operating at W-band or beyond), superconducting magnets are being used. The state-of-the-art magnets employ cryogen free superconducting magnet technology. Which eliminates the need of re-filling of liquid helium. Some researchers have reported gyrotrons developed with Samarium-Cobalt ($\text{Sm}_2\text{Co}_{17}$) permanent magnets and special type of room temperature solenoid made out of copper foil. Such gyrotrons usually operate at higher harmonic mode of interaction.

5. Applications of gyrotrons

Gyrotrons have wide range of applications. These applications covers the domain of scientific research, industrial heating, homeland security and defense. Same is shown in tree diagram (**Figure 13**).

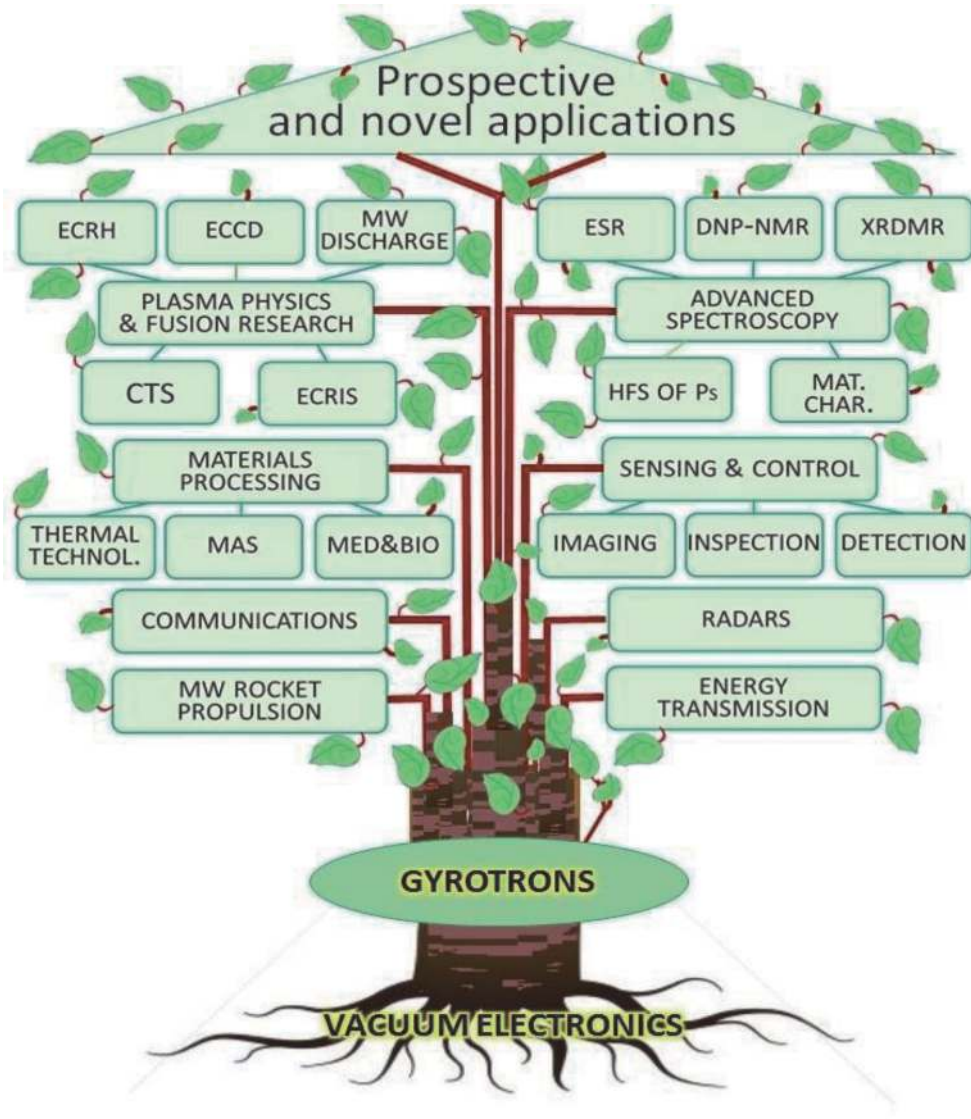

Figure 13.
 Applications of gyrotron.

5.1 Major application

Majority of gyrotrons developed worldwide are being used for the electron cyclotron resonance heating (ECRH) of plasma in the controlled thermoneuclear fusion reactor [7]. The plasma is kept confined in the plasma vessel with the help of very high value of superconducting magnetic field (magnetic confinement). The magnetically confined plasma is then exposed to very high power millimeter wave beam generated with the help of a gyrotron. This elevates the temperature of the plasma to 100000°C . At this temperature, fusion reaction takes place. Millimeter-wave beam generated by a gyrotron is also used for the electron cyclotron current drive (ECCD), electron cyclotron resonance ion source (ECRIS) and also for the diagnostics cooling tower system (CTS). For the ITER (international thermoneuclear experimental reactor) project, it's proposed to use 20 numbers of 170 GHz long-pulse gyrotrons to generate combined heating power of 24 MW. For this purpose, till now, the highest order mode number attempted is $\text{TE}_{34,19}$ for the generation of 2 MW of continuous

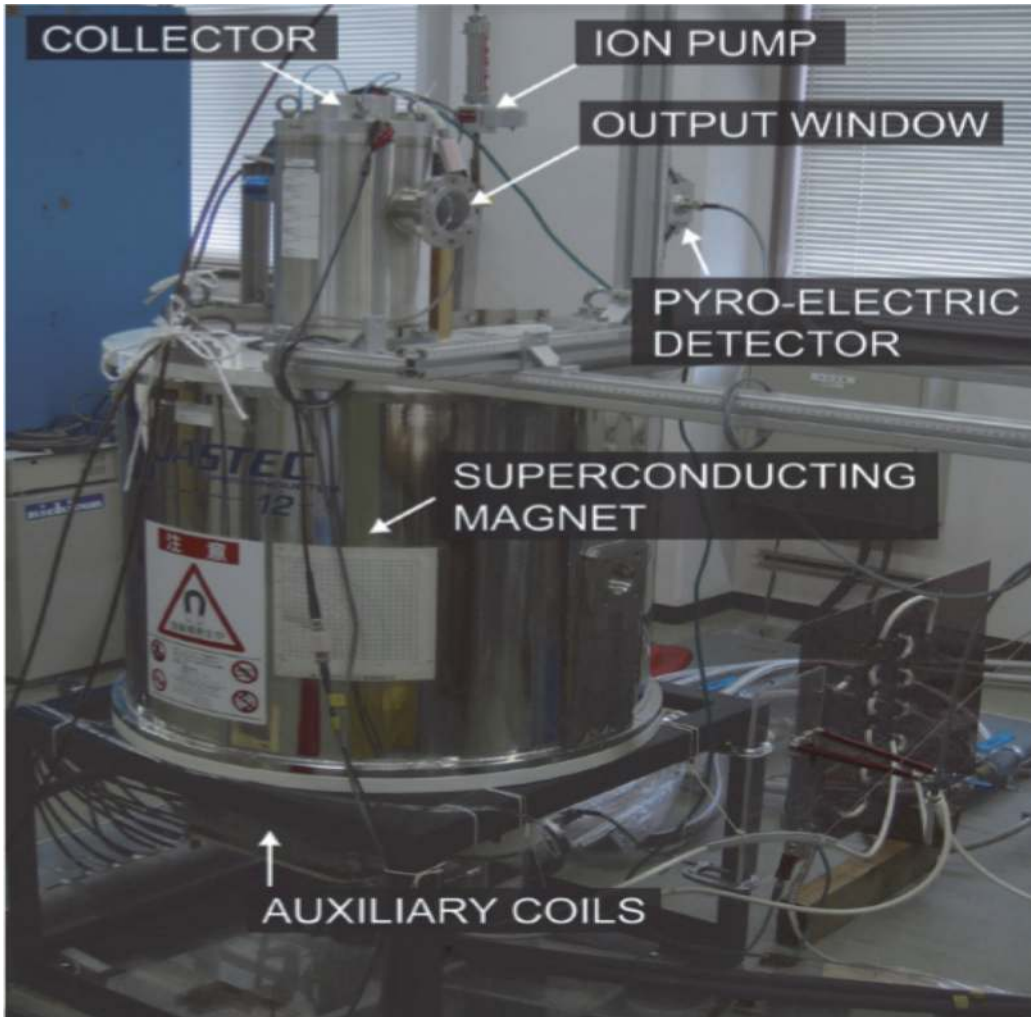

Figure 14.
2 MW Gyrotron for ECRH application.

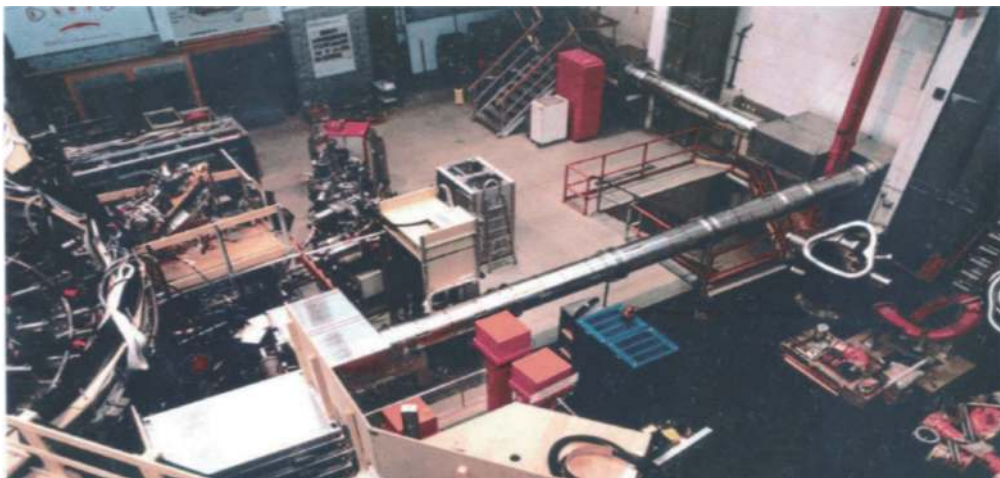

Figure 15.
140 GHz Gyrotron based ECRH system (Stellarator W7-AS).

power at 170 GHz. The photograph of a 2 MW gyrotron for ECRH application is shown in **Figure 14**. The photograph of a ECRH System (Stellarator W7-AS) with 140 GHz gyrotron is shown in **Figure 15**.

5.2 Other applications of gyrotron

Other important scientific research application of gyrotron is in the area of spectroscopy. This includes, electron spin resonance (ESR) spectroscopy, dynamic nuclear polarization – nuclear magnetic resonance (DNP-NMR) Spectroscopy, X-ray diffraction magnetic resonance (XRDMR) spectroscopy etc. Also, W- band frequency of 95 GHz being an atmospheric window, gyrotrons operating at W-band are having special significance in connection with defense and homeland-security [17, 18]. The active denial systems (ADS) for controlling low-intensity conflicts, uses 95 GHz gyrotron. Also a number of millimeter-wave radar systems, such as space surveillance radar, space derby radar, imaging radar and weather radar uses W-band gyrotron as well as gyro-TWT/ gyro-klystrons.

6. Worldwide scenario of gyrotron for plasma heating

Worldwide, a number of research institutions, academic institutions and industries are working in the field of gyrotron, with frequency varying from lower end of microwave range (8 GHz) to 1 THz. The output power of these gyrotrons also ranges from 100 s of kW to few MW. Pulse duration also varies from few milliseconds to full continuous wave (CW) operation. The efficiency of gyrotron varies from 10–70%. The worldwide scenario of Gyrotron for plasma heating purpose are presented in the **Tables 3** and **4** [7, 11–13, 19–21].

Institute	Frequency (GHz)	Mode		Power (MW)	Efficiency (%)	Pulse length (Sec)
		Cavity	Output			
CPI, USA	28,35	TE ₀₂	TE ₀₂	0.2	37	CW
CPI, USA	53.2,56,60,70	TE _{01/02}	TE ₀₂	0.23	37	CW
CPI, USA	70.15	TE _{10,3}	TEM ₀₀	0.6	47 (SDC)	2.25
CPI, USA	84	TE _{15,4}	TEM ₀₀	0.56	44 (SDC)	2.0
CPI, USA	94.9	TE _{6,2}	TEM ₀₀	0.12	50 (SDC)	CW
Gycom, Russia	68 (70)	TE _{9,3}	TEM ₀₀	0.5 (0.68)	50 (48) (SDC)	1.0 (3.0)
Gycom, Russia	75	TE _{11,5}	TEM ₀₀	0.8	70 (SDC)	0.1
Gycom, Russia	82.7	TE _{10,4}	TEM ₀₀	0.65	53 (SDC)	0.3
Gycom, Russia	82.7	TE _{10,4}	TEM ₀₀	0.9	32	0.3
Gycom, Russia	82.7	TE _{10,4}	TEM ₀₀	0.2	52 (SDC)	CW
Gycom, Russia	84	TE _{12,5}	TEM ₀₀	0.88	54 (SDC)	3.0
Gycom, Russia	84	TE _{12,5}	TEM ₀₀	0.5 (0.2)	50 (SDC)	10 (CW)
Hughes	60	TE ₀₂	TE ₀₂	0.2	35	0.1
IECAS, China	24.1	TE ₀₁	TE ₀₁	0.15	24	0.02
IECAS, China	34.3(2Ωc)	TE _{02/03}	TE ₀₃	0.2	30	0.02
Mitsubishi, Japan	88	TE _{8,2}	TEM ₀₀	0.35	29	0.1
NEC, Japan	35	TE ₀₁	TE ₀₁	0.1	30	0.001
NRL, USA	35	TE ₀₁	TE ₀₁	0.15	31	0.02
Philips, Germany	70	TE ₀₂	TE ₀₂	0.14	30	CW

Institute	Frequency (GHz)	Mode		Power (MW)	Efficiency (%)	Pulse length (Sec)
		Cavity	Output			
Toshiba, Japan	77	TE _{18,6}	TEM ₀₀	1.2	38 (SDC)	10.0
Toshiba, Japan	77	TE _{18,6}	TEM ₀₀	0.3	36 (SDC)	900
UESTC, China	70(2Ωc)	TE _{02/03}	TE ₀₃	0.1	20	0.0001
UESTC, China	94(2Ωc)	TE _{02/03}	TE ₀₃	0.12	20.5	0.0001
	94	TE _{61/62}	TE _{61/62}	0.09	43	CW

SDC: Single-Stage Depressed Collector; CW: Continuous Wave Operation.

Table 3.
Gyrotrons for electron cyclotron resonance heating, 28–95 GHz.

Institute	Frequency (GHz)	Mode		Power (MW)	Efficiency (%)	Pulse length (Sec)
		Cavity	Output			
CPI, USA	140	TE _{02/03}	TE ₀₃	0.1	27	CW
CPI, USA	140	TE _{15,2}	TE _{15,2}	0.32	31	3.6
CPI, USA	140.2	TE _{28,7}	TEM ₀₀	0.9	33 (SDC)	1800
KIT, Germany	140.8	TE ₀₃	TE ₀₃	0.12	26	0.4
KIT, Germany	162.3	TE _{25,7}	TEM ₀₀	1.48	35	0.007
KIT, Germany	139.8	TE _{28,8}	TEM ₀₀	1.0	50 (SDC)	12
KIT, Germany	139.8	TE _{28,8}	TEM ₀₀	0.92	44 (SDC)	1800
Gycom, Russia	140	TE _{22,6}	TEM ₀₀	0.96	36	1.2
Gycom, Russia	140	TE _{22,6}	TEM ₀₀	0.54	36	3.0
Gycom, Russia	140	TE _{22,6}	TEM ₀₀	0.1	35	80
Gycom, Russia	170	TE _{25,10}	TEM ₀₀	1.0	53 (SDC)	570
Gycom, Russia	170	TE _{25,10}	TEM ₀₀	0.8	55 (SDC)	1000
Gycom, Russia	140	TE _{22,6}	TEM ₀₀	0.8	32	0.8
Gycom, Russia	140	TE _{22,6}	TEM ₀₀	0.88 50	50.5(SDC)	1.0
Toshiba, Japan	170	TE _{31,8}	TEM ₀₀	1.3	32	0.003
Toshiba, Japan	170	TE _{31,12}	TEM ₀₀	1.56	27	0.1
Toshiba, Japan	168	TE _{31,8}	TEM ₀₀	0.52	19	1.0
Toshiba, Japan	168	TE _{31,8}	TEM ₀₀	0.52	30 (SDC)	1.0

Table 4.
Gyrotrons for electron cyclotron resonance heating, above 140 GHz.

Acknowledgements

The authors are thankful to Dr. M.V. Kartikeyan, professor, Indian Institute of Technology (IIT)-Tirupati, India, for his valuable suggestions and inputs. The authors are also thankful to Sri G. Viswam, Center Head, Microwave Tube Research & Development Center (MTRDC), Bangalore, India, for his necessary help and support. Also, the authors are thankful to Shroyonaa Karmakar, Jain University School of Design, for the preparation of the diagrams.

Author details

Santanu Karmakar^{1,2*} and Jagadish C. Mudiganti³

1 VIT University, Vellore, India

2 MTRDC, Bangalore, India

3 VIT AP University, Amaravati, India

*Address all correspondence to: santanukarmakar@yahoo.com

IntechOpen

© 2021 The Author(s). Licensee IntechOpen. This chapter is distributed under the terms of the Creative Commons Attribution License (<http://creativecommons.org/licenses/by/3.0>), which permits unrestricted use, distribution, and reproduction in any medium, provided the original work is properly cited. 

References

- [1] Basu B.N., “Electromagnetic Theory and application in Beam-Wave Electronics”, World Scientific, Singapore, 1996
- [2] Gilmour, A.S. Jr. “Microwave Tubes”, Artech House, USA, 1986
- [3] Gilmour, A.S. Jr. “Klystrons, Traveling Wave Tubes, Magnetrons, Crossed-Field Amplifiers, and Gyrotrons”, Artech House, USA, 2011
- [4] Rowe, J.E., “Non-linear Electron wave interaction phenomenon”, Academic Press, New York, 1965.
- [5] D. E. Baldwin, “Advances in Plasma Physics”, vol. 3, John Wiley & Sons, New York, 1969.
- [6] M. V. Kartikeyan, E. Boris, M.K.A. Thumm, “Gyrotrons: High Power Microwave and Millimeter Wave Technology”, Springer-Verlag, Berlin, Heidelberg, 2004
- [7] M K.A. Thumm, State-of-the-art of high power gyro- devices and free electron masers, Update 2016, KIT, Karlsruhe, Germany, 2017.
- [8] G. S. Nusinovich, Introduction to the Physics of Gyrotron, Maryland: JHU, USA, 2004.
- [9] C. J. Edgecombe, Gyrotron Oscillators: Their principles and practice, Taylor & Francis Ltd., London, 1993.
- [10] Shulim E. Tsimring, “Electron Beams and Microwave Vacuum Electronics”, Wiley-Interscience, 2007
- [11] Barker, R.J. and E. Schamiloglu, “High Power Microwave Sources and Technologies”, IEEE Press, New York, 2001
- [12] Barker R.J., J.H. Booske, N.C. Luhmann and G.S. Nusinovich, “Modern Microwave and Millimeter Wave Power Electronics”, IEEE Press, NJ, 2005
- [13] Victor L. Granstein and Igor Alexef, “High power microwave sources”, Artech House, London
- [14] Flyagin, V. A., Gaponov, A.V., Petelin, M.I. and Yulpatov, V.K., The Gyrotron, IEEE. Trans. Microwave Theory and Tech., vol. 25, pp 514 – 512, 1977
- [15] Idehara T., I. Ogawa, S. Mitsudo, “A high harmonic Gyrotron with an axis-encircling electron beam and a permanent magnet”, IEEE Trans. Plasma Sci., vol. 32, pp 903, 2004
- [16] Shahana K, Vishal Kesari, Shantanu Karmakar, R. Seshadri, “Simulation of TE_{6,2} to Gaussian Mode Converter for a 95 GHz Gyrotron”, IEEE Trans. Plasma Science, vol. 46, Issue 1, pp 84-89, 2018.
- [17] Alastair D. McAulay, Military Laser Technology for Defense, John Wiley & Sons, 2011.
- [18] Tolkachev A.A., B.A. Levitan, G.K. Solovyev, “A megawatt power millimeter wave phased-array radar”, IEEE Trans. Aerosp. Electron. Syst., vol. 25, pp25, 2000
- [19] Glyavin M., A.L. Goldenberg, A.N. Kufin, “Experimental studies of Gyrotron electron beam systems”, IEEE Trans. Plasma Sci., vol 27, pp 474, 1999
- [20] C. D. Marchewka, E. M. Choi, M. A. Shapiro, J. R. Sirigiri, and R. J. Temkin, “Observation of low-frequency paracitic oscillations in 1.5 MW, 110 GHz gyrotron,” Proc. IEEE Int. Vacuum Electronics Conf., p. 535, May 2006.
- [21] S. Sabchevski and I. Zhelyazkov, “Modeling and simulation of new generation powerful gyrotrons for the fusion research,” J. Phys. Conf. Series, vol. 63, pp. 012003-1-11, Jan. 2007.