Synthetic Methods for Titanium Dioxide Nanoparticles: A Review

Pardon Nyamukamba, Omobola Okoh,
Henry Mungondori, Raymond Taziwa and
Simcelile Zinya

Additional information is available at the end of the chapter

<http://dx.doi.org/10.5772/intechopen.75425>

Abstract

Titanium dioxide (TiO₂) semiconductor nanoparticles are one kind of important and promising photocatalysts in photocatalysis because of their unique optical and electronic properties. Their properties, which are determined by the preparation method, are very crucial in photocatalysis. In this chapter, an overview was carried out on the different methods that are used or have been used to prepare titanium dioxide nanoparticles. There are various methods that can be used to synthesize TiO₂ and the most commonly used methods include sol-gel process, chemical vapor deposition (CVD) and hydrothermal method among others. This review will focus on selected preparation methods of titanium dioxide photocatalyst.

Keywords: titanium dioxide, synthetic methods, photocatalyst, semiconductor

1. Introduction

Titanium dioxide photocatalyst is a well-known and well researched photocatalyst due to its interesting properties which include stability, non-toxicity, biocompatibility, optical and electrical properties. It exists mainly in three different forms namely anatase, rutile and brookite and their structures are shown in **Figure 1** [1]. Upon heating, both anatase and brookite convert to rutile which is more stable at all temperatures and pressures below 60 kbar, according to thermodynamic calculations [2]. **Table 1** shows some of the structural and physical properties of the anatase and rutile phase of titanium dioxide [3].

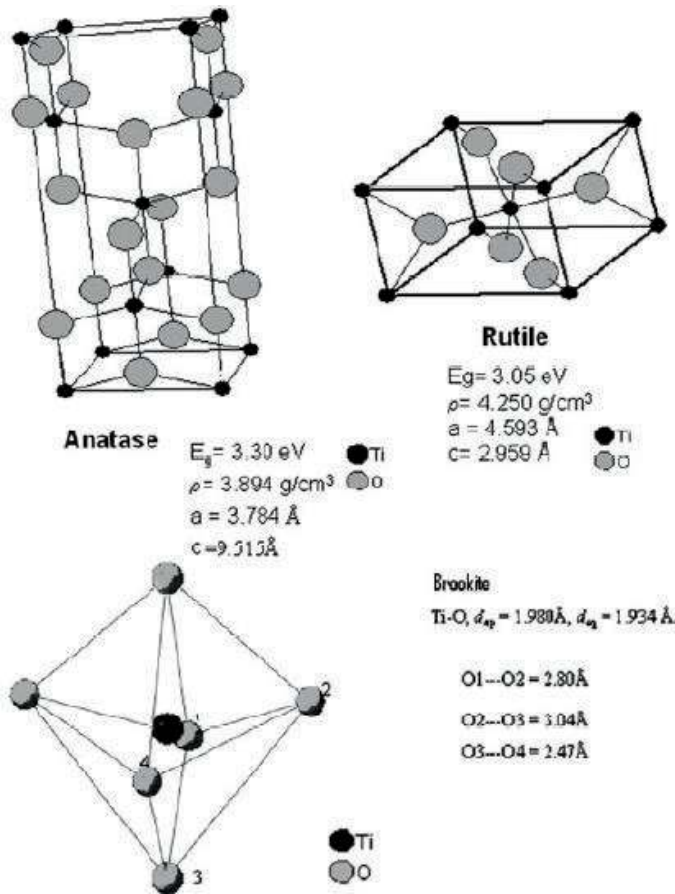

Figure 1. Different forms titanium dioxide [1].

The recent development of nanotechnology has proved that nanomaterials such as nano-sized titanium dioxide photocatalysts can have high activity in the photodegradation of a wide range of organic and inorganic contaminants in water. It is believed that photocatalysis will soon be recognized as one of the most effective means of dealing with various kinds of wastewater since organic pollutants can be completely degraded to harmless matter under normal conditions of temperature and pressure.

It is capable of degrading pollutants such as herbicides, carboxylic acids and alcohols completely to carbon dioxide, water and simple minerals [4]. For it to be very effective, it should have certain properties such as suitable particle size, shape, crystallinity and a good ratio of anatase to rutile. This is the reason why most researchers have been trying to use different methods to get particles with suitable characteristics for environmental remediation or for other applications of interest. Several studies have proved that TiO_2 nanostructures, in particular, titanium dioxide nanotubes (TNTs) have their performance improved in photovoltaics [5]

Property	Anatase	Rutile
Molecular weight (g/mol)	79.88	79.88
Melting point (°C)	1825	1825
Boiling point (°C)	2500–3000	2500–3000
Specific gravity	3.9	4.0
Light absorption (nm)	$\lambda \leq 385$ nm	$\lambda \leq 415$ nm
Mohr's hardness	5.5	6.5 to 7
Refractive index	2.55	2.75
Dielectric constant	31	114
Crystal structure	Tetragonal	Tetragonal
Lattice constants (Å)	a = 3.784 c = 9.515	a = 4.5936 c = 2.9587
Density (g/cm ³)	3.79	4.13
Ti–O bond length (Å)	1.937 (4) 1.965 (2)	1.949 (4) 1.980 (2)

Table 1. Properties of the anatase and rutile phase of titanium dioxide [3].

and photocatalysis [6] compared to nanoparticulate forms of titanium oxide. Recently, bundles and arrays of TNTs with different qualities have been synthesized by a variety of different techniques such as template-assisted, sol-gel, hydrothermal, electro-anodization, chemical vapor deposition and physical vapor deposition [7].

There are other various techniques for preparing titanium dioxide (TiO₂) nanoparticles and these include reverse micelles, the sol-gel process, the metal organic chemical vapor deposition (MOCVD) [8], gas phase (aerosol) synthesis [9], wet-chemical synthesis by precipitation of hydroxides from salts, microemulsion-mediated methods [10] and electrochemical synthesis. These methods can be divided into five general groups namely sol-gel, deposition methods, sonochemical and microwave-assisted methods, hydro/solvothermal methods and oxidation methods.

2. Synthetic methods

2.1. Deposition methods

In these methods, materials in the vapor state are condensed to form a solid phase material. The process is normally carried out in a vacuum chamber and if a chemical reaction takes place, it is called chemical vapor deposition (CVD) and physical vapor deposition (PVD) if no reaction occurs. Examples of CVD include electrostatic spray hydrolysis, diffusion flame pyrolysis, thermal plasma pyrolysis, ultrasonic spray pyrolysis, laser-induced pyrolysis and

ultrasonic-assisted hydrolysis. TiO_2 films with grain size less than 30 nm and TiO_2 nanoparticles with sizes less than 10 nm were synthesized by pyrolysis of titanium tetraisopropoxide (TTIP) in a helium/oxygen atmosphere [11]. Thermal plasma synthesis [12] and spray pyrolysis [13] have been used in some studies but they are complex, capital and energy-intensive and the properties of the powder are not easy to control.

2.1.1. Electrophoretic deposition

This is the most favored method due to several reasons, which include effectiveness in the fabrication of coatings and films from suspensions [14], a short period of time is required for deposition, the ability to deposit a film on a non-uniform surface, it is cost effective, it is easy to control the thickness of the films, ability to utilize suspensions of low solids loadings, homogeneity of resultant coatings, simple apparatus requirements, binder-free process and it is possible to prepare homogeneous coated layers or deposited films [15, 16].

The process involves the movement of charged particles in a suspension medium followed by deposition on a substrate under an applied DC voltage [17, 18] as shown in **Figure 2**. When the voltage is applied to the electrodes, an electric field is created that interacts with the surface charge of the nanoparticles, producing a force that makes the particle move toward the electrode of the opposite charge and their accumulation on this electrode leads to the formation of a homogeneous layer.

Different thickness of the films can be achieved by changing the deposition parameters such as voltage, deposition time, solvent type, zeta potential particle and loading in the suspension [17]. Some researchers have used different combinations in titanium dioxide thin film

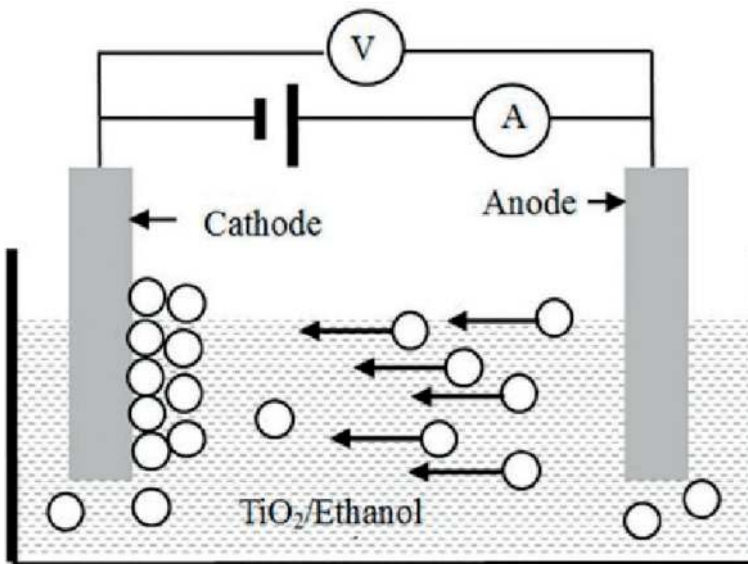

Figure 2. Schematic setup of the electrophoretic deposition cell [16].

deposition for different applications such as biomedical applications [19], ceramic coatings [20] and dye-sensitized solar cells [21–23]. Nyongesa and Aduda used electrophoretic deposition technique to deposit titanium dioxide thin films on conducting glass substrates for application in water purification [16]. In the study, they found out that ethanol was a better solvent to use compared to toluene, propanol or water, which they believed was due to its high dielectric constant (ϵ) of 24.3. Water is not a suitable suspension medium due to water electrolysis which takes place during the deposition and this can cause gas bubbles to accumulate at the electrode surfaces, which is detrimental to the electrophoretically deposited coating. The best parameters for good adherence of the nanoparticles were: pH value of 3, solid loading of 4.0 wt% and a voltage of 20 V [16]. In a similar study by Nguu et al. [24], to achieve a uniform film of 5 μm , the best voltage and time were 35 V and 90 s, respectively, and they discovered that extended deposition times (>90.0 s) resulted in formation of agglomeration [24]. In another study by Dhiflaoui et al., it was found that the coatings deposited at 20 V for 4 min were the most homogeneous [25]. They also discovered that transformation of anatase to rutile depends on the electric current in the electrochemical cell. When the voltage is increased, the modulus of elasticity and hardness of the films also increase.

2.1.2. *Spray pyrolysis*

This is a deposition technique that enabled production of a variety of products in the form of fine dispersive porous or dense powders or films. The first reactors for nanoparticles by flame synthesis (FS) started in the 1940s, to produce fumed silica. In 1971, G.D. Ulrich reported the first principles of the FS method. Silica and titanium dioxide were the first materials to be produced by flame synthesis and patented [26] but with time TiO_2 became the largest material produced by flame aerosol reactors [9]. The number of researchers using FS has increased in the last years.

Generally, this method can be divided into two groups that are spray pyrolysis synthesis (SPS), which results in powders and spray pyrolysis deposition (SPD), which results in thin films. The method involves the passing of precursor's flux across a direct flame. It can proceed either by supplemental burners that are mounted near the spray nozzle, or by additional feeding of the nozzle by oxidant that could be air or pure oxygen and the combustibles. If an organic solvent is used, it can serve as a flame fuel as well. A nozzle or a nebulizer can be used but the use of a nozzle implies that the diameter of the spray droplets depends on the diameter of the nozzle outlet tip, the surface tension of the respective precursor solution, its viscosity and the pressure difference before and after the spraying [27]. Kozhukharov and Tchaoushev [28] recommended the production of ultrafine dispersive powders by swift rise of the temperature inside the chamber. In this process, the already formed solid particles undergo further splitting, due to mechanical tensions and or phase transitions occurring [28].

Adhesion to the substrate is important for the quality of the deposited film which means SPD could be performed either directly by hot spray, or by cold spray on preliminary heated substrate. Several parameters of the pyrolysis process, such as the size of the spray droplets, chemical composition of the obtained products, their crystal phases and density can be controlled. Selection and precursor preparation is a challenging task when multi-component materials are to be produced. The precursor should be fed into the reactor at low pulsation

rates as sprays are sensitive to oscillations in the liquid fuel supply which can affect nanoparticle growth conditions. When the flow rate of the precursor is increased, the particle diameter also increases but decreases when the dispersion gas flow rate is increased as a result of rapid mixing reactants and oxidizers [29].

Some important advantages of this technique include the possibility to produce uniform and dense films which have desirable crystallinity by multiple repetitions of spraying and or annealing cycles and the ability to fabricate entire multilayer devices by subsequent deposition of different functional layers, in the same chamber [27]. In spray pyrolysis methods, nanoparticles and thin films are produced in a one-step process and there is no need for further purification or excessive drying procedures, which could have a negative impact on the total thermal budget and cost of production of titanium dioxide nanoparticles [30]. Besides the above mentioned advantages, there are some limitations of this method and these include the need to control temperature and the difficulty in obtaining low temperature allotropic forms of the respective products hence in a large scale production, there is a need for cooling systems, and precise temperature control.

With a lot effort being put in trying to develop the technique, a new spray pyrolysis setup has been designed to overcome limitations of previous systems such as reproducibility, temperature control, gas flow rate and solution rate accuracy. The new system is almost fully computerized. A schematic representation of the spray pyrolysis system is shown in **Figure 3**.

2.2. Oxidation methods

These methods involve the oxidation of titanium metal using oxidants or anodization. Anodization of titanium sheet under a voltage between 10 and 20 V in 0.5% hydrogen fluoride

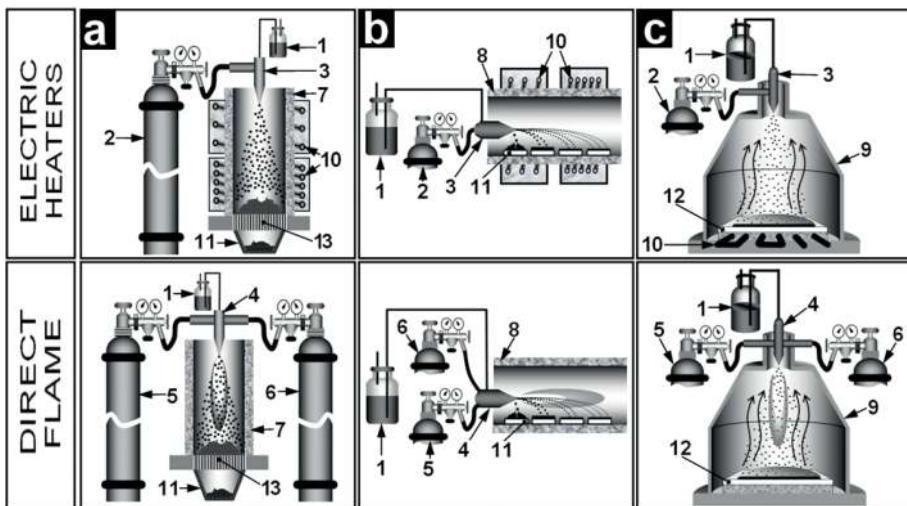

Figure 3. Schematic representation of spray pyrolysis system: (a) vertical chambers; (b) horizontal chambers and (c) chambers for film deposition [27].

leads to the formation of aligned TiO₂ nanotubes whose diameter is controlled by varying the applied voltage [31]. In another study, crystallized TiO₂ nanotubes were obtained when anodized titanium plate was heat treated at 500°C for 6 h in an oxygen environment [32]. Direct oxidation of the titanium metal with hydrogen peroxide has also been found to lead to the formation of TiO₂ nanorods. The TiO₂ can be obtained by placing a cleaned Ti metal plate in a 50 mL solution of 30 wt% H₂O₂ at 353 K for 72 h [33]. Formation of crystalline TiO₂ occurs via mechanism of dissolution precipitation and this phase can be controlled by addition of NaX (X = F⁻, Cl⁻, SO₄²⁻) inorganic salts. Addition of Na₂SO₄ and NaF results in the formation of anatase phase and when rutile phase is needed, NaCl can be added during dissolution precipitation [34].

Acetone, pure oxygen and a mixture of oxygen and argon can be used as sources of oxygen for oxidation of titanium metal. Acetone is a good source of oxygen and when used at high temperatures, it results in nanorods which are well aligned and highly dense. Use of pure oxygen or a mixture of oxygen and argon results in crystal grain films and morphology of the nanoparticles can be controlled by the diffusion competition of oxygen and titanium [8].

2.3. Sonochemical and microwave-assisted methods

The sonochemical method has been applied to produce highly photoactive TiO₂ nanoparticles by the hydrolysis of titanium tetraisopropoxide (TTIP) in pure water or in an ethanol/water mixture under ultrasonic radiation [35]. Sonochemistry arises from *acoustic cavitation* which is the formation, growth and collapse of bubbles within a liquid medium. Heat (~5000 K) and high pressures (~1000 atm) are produced by cavitation collapse [31].

In microwave-assisted methods, there is a use of microwaves which are electromagnetic waves with frequencies which range from 0.3 to 300 GHz and with wavelengths between 1 mm and 1 m. According to Zhu and Chen [36], microwave heating involves two main mechanisms namely dipolar polarization and ionic conduction. Any materials that contain mobile electric charges such as polar molecules or conducting ions are generally heated by microwaves. In the microwave, heat is generated by rotation, friction and collision of molecules as polar molecules try to orientate with the rapidly changing alternating electric field. If ions are present in solution, they will move through the solution and constantly change directions based on the orientation of the electric field resulting in local temperature rise due to friction and collision [37].

Microwave heating is as an alternative heat source for rapid heating with shorter reaction time and higher reaction rate, selectivity and yield as compared to the conventional heating methods [36]. There are two types of microwave heating: pulsed microwave heating and continuous microwave heating. Jacob et al. in 1995 proposed two models of the mechanism for microwave-induced reaction rate enhancements. The first mechanism assumes that, although the reaction time is heavily shortened for a microwave-induced reaction, the kinetics or mechanism of the chemical reaction is not altered implying that the enhancement of the reaction rate is due to the thermal heating effect [38]. The second proposed mechanism makes an assumption that there are “nonthermal microwave effects” in addition to the thermal effects hence the effects of microwave irradiation in chemical reactions are due to both thermal effects and nonthermal effects [39]. The nonthermal effects are due to direct interaction of microwaves with certain molecules in the reaction medium.

Microwave radiations can also be applied to produce various TiO_2 nanomaterials [40]. In industrial processing, this method has an advantage of rapid heat transfer and selective heating. This technique provides uniform distribution of energy within the sample, better reproducibility and excellent control of experimental parameters. The colloidal TiO_2 nanoparticles can be prepared in a short period of time (within 5–60 min) compared to several hours needed for the conventional methods of forced hydrolysis at high temperatures ($\sim 195^\circ\text{C}$) [41]. TiO_2 nanotubes which are open-ended and multi-walled with diameters of 8–12 nm and lengths between 200 and 1000 nm were also prepared using this method [33]. TiO_2 nanoparticles in the anatase phase were prepared by Baldassari et al. [42] using microwave-assisted hydrolysis of titanium tetrachloride (TiCl_4) in a dilute acidic aqueous medium. They found out that the product almost completely crystallized in a short reaction time of 30 min under microwave-hydrothermal conditions. The acid that they used was to obtain a pure anatase phase was H_2SO_4 since the sulfate prevented the crystallization of brookite. In another study, they also prepared TiO_2 nanoparticles in the rutile phase from TiCl_4 by a microwave-hydrothermal process at different temperatures between 100 and 160°C for 5–120 min [42]. The morphology and size of the resulting nanoparticles can be varied by changing the time of reaction, microwave power and reactant concentration.

2.4. Hydro/solvothermal methods

These are two processes, solvothermal and hydrothermal which are almost similar. The hydrothermal method is a process of crystallizing a substance at a high temperature and high vapor pressure using an aqueous solution of the material [43]. It is commonly depicted as crystal synthesis or crystal growth from substances which are insoluble in customary temperature (100°C) and pressure (<1 atm). The process is carried out in autoclaves under controlled temperature and pressure. It allows the use of temperatures above the boiling point of water/organic solution. Hydrothermal synthesis is characterized as a concoction response occurring in a dissolvable at temperatures over the dissolvable breaking point and at pressures above bar. Compared to hydrothermal method, the solvothermal method uses a non-aqueous solvent, has better control of the properties of TiO_2 and the temperature can be increased much higher meaning high boiling point solvents can be used. The hydrothermal strategy exploits that by expanding temperature and pressure the essential properties of water and consequently its capacities as a solvent changes. Important characteristics such as the ionic product density, thermal conductivity, viscosity, heat capacity and the dielectric constant are all highly pressure and temperature dependent and by tuning the synthesis parameters, specific solvent properties can be obtained. Feng et al. [44] produced TiO_2 nanorods by treating titanium tetrachloride solution saturated with sodium chloride at 160°C for 2 h. Kim et al. [45] used the solvothermal method to prepare TiO_2 of good quality without the use of surfactants.

The first report of the hydrothermal growth of crystals was by a German geologist Karl Emil in 1845 [46]. The hydrothermal method can be used to synthesize a single crystal of the material depending on the solubility of the material in the solvent. Single crystal growth is done in a high pressure vessel called an autoclave. These are hermitically sealed steel vessels that can withstand high temperatures and pressure for long durations. Also, the vessel must be chemically inert and must not take part in the hydrothermal process. A number of substances such as oxides [47], tungstate [48], molybdates [49], carbonates [50] and silicates [51] can be

synthesized. The different approaches in the hydrothermal technique can be broadly classified as temperature-difference technique, temperature-reduction technique and metastable-phase technique [52]. Temperature-difference technique is a method in which the autoclave is heated to two temperature zones. The solute dissolves in the hotter zone (lower part) and the saturated solution moves from the lower part to the upper part (at a relatively lower temperature) due to the difference in temperature. The cooler solution in the upper portion descends to the lower part resulting in a counter flow. Eventually, the solution in the upper part becomes supersaturated due to the reduction in temperature and the material starts to crystallize. Temperature-reduction technique is a method in which instead of having the two temperature zones, the autoclave is slowly cooled down with the saturated solution inside it. However, this technique has the disadvantage of difficulty in controlling the growth process. Metastable-phase technique is a method based on the difference in solubility between the crystal growth phase and that serving as the starting material. The solution consists of compounds that are thermodynamically unstable under the growth conditions. The solubility of the compounds that are in the metastable phase is more than that of its stable phase. The compounds crystallize due to the decomposition of the metastable phase.

The advantages of the hydrothermal method are that it is an easy method to obtain nanotube morphology, variation in the synthesis method can be implemented to enhance the properties of TiO₂ nanotubes, and it is a feasible method for different applications. However, the disadvantages include long synthesis duration, the need for a highly concentrated NaOH solution (contaminating the TiO₂ nanotubes with NaOH) and precisely controlling the diameter of the nanotubes [53]. Furthermore, hydrothermal methods are disadvantaged by the high cost of equipment and the inability to monitor crystals in the process of their growth. Hydrothermal synthesis cannot be affected at both temperatures and pressures below the critical point for a specific solvent above which differences between liquid and vapor disappear, and can only take place under supercritical conditions. The hydrothermal method is affected by alkaline concentration, temperature and reaction time. Temperature is important for promoting growth of crystals and nucleation of nanoparticles. Generally, as temperature increases, the yield, length and degree of crystallinity of nanotubes also increase and with the optimal temperature between 100 and 200°C. As hydrothermal time increases, yield also increases, but prolonged hydrothermal time results in morphological changes of nanoparticles, for example, nanotubes to nanofibers [54].

Solvothermal method allows shape, control of size, distribution and crystallinity of TiO₂ nanoparticles better than the hydrothermal method. These can be achieved by controlling the following parameters; solvent, addition of surfactants, titanium precursors, reaction temperature and reaction time [55]. Use of organic solvents in the solvothermal method results in a product that is free from foreign anions since organic solvents exhibit low relative permittivity as well as being free from ionic species.

2.5. Sol-gel methods

Sol-gel process is a wet-chemical technique that is mostly used in the field of materials science and ceramic engineering. It can be defined as the conversion of a precursor solution to an inorganic solid through polymerization reactions induced by water. Hydrolysis forms a sol which

is basically a dispersion of colloidal particles in a liquid, and condensation leads in the formation of a gel. Compared to the methods discussed above, the sol-gel process is very promising for synthesis and preparation of inorganic and organic-inorganic hybrid nanomaterials because it allows the use of low processing temperatures (<100°C) and molecular level composition homogeneity [56]. Particle size and shape are easy to control using the sol-gel method.

The sol-gel process produces fine, spherical powders of uniform size and has been widely used to synthesize TiO₂ materials and normally proceeds via an acid-catalyzed step of titanium (IV) alkoxides [57]. One of the most attractive features of the sol-gel process is the possibility to shape the resulting material into desired forms such as fiber, film and monodispersed powder. Several steps and conditions are applied in a sol-gel process to control the final morphology as suggested by Mehrotra and Singh [58] in **Figure 4**.

Typical precursors are metal oxides and metal chlorides. A metal alkoxide consists of an M—O—R linkage where M is the metal, O is oxygen and R is an alkyl group. The polarization that takes place in the M—O bond makes it susceptible to nucleophilic attack. In the presence of water, the alkoxide undergoes a nucleophilic substitution reaction in which the alkoxy groups (OR) are replaced by the hydroxyl groups from water and this process is called hydrolysis. The metal hydroxide groups will link and generate a hydrated metal-oxide network which eventually forms small nuclei and this process is called condensation.

The chemistry, hydrolysis and poly condensation reactions are very convenient to obtain both polymeric and particulate titanium sols:

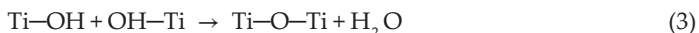
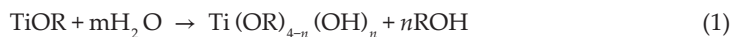

Polycondensation turns monomers into oligomers and, lastly, polymers. As long as the number of alkoxide groups, is greater than 2, complex random branching may occur finally leading to fractal structures.

Metal alkoxides used for the sol-gel process are generally very reactive and thus there is need for controlling the reactivity in order to obtain sols and gels with desirable properties by using modifiers or addition of chelating ligands such as β-diketones, carboxylic acids or other complex ligands [56]. These modifiers react with alkoxides giving rise to new molecular precursors that can be used in sol-gel processing to provide better control of the hydrolysis-condensation process. These new precursors reduce reactivity and functionality, prevent condensation and lead to formation of species that are smaller. Livage et al. in 1988 investigated the use of acetylacetone to improve the sol-gel processing of metal alkoxides [59].

Modification by modifiers reduces the number of M—OR bonds available for hydrolysis and thus hydrolytic susceptibility. If β-diketones are used, they decrease the nuclearity resulting in small particles since these ligands are surface capping reagents and polymerization lockers. Carboxylate ligands such as acetic acid mostly act as bridging chelating ligands.

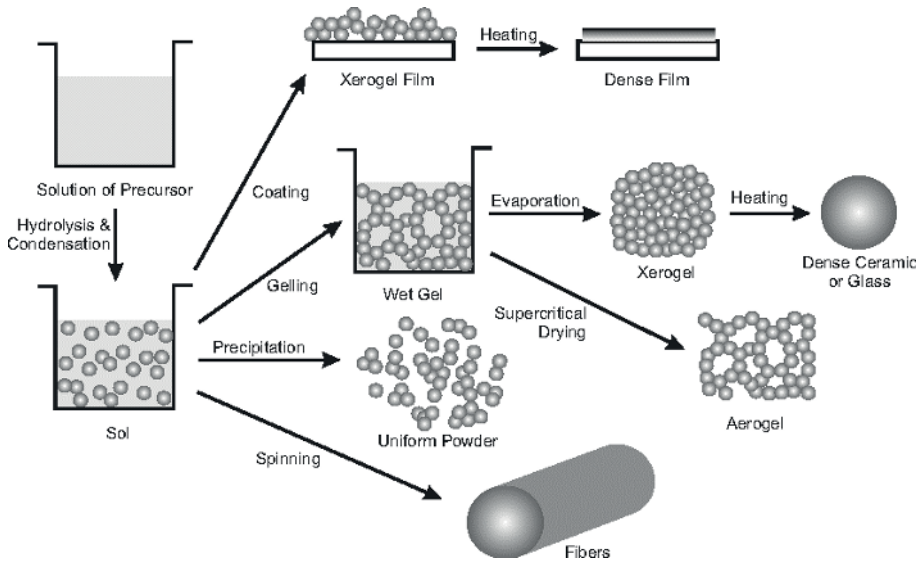

Figure 4. Different sol-gel process steps to control the final morphology of the product [58].

There are several advantages of the sol-gel process and these include [60]: (i) use of low temperatures during preparation, (ii) easy and effective control of particle size, shape and properties, (iii) better homogeneity from raw materials, (iv) better purity from the starting materials and it is possible to design the material structure and property through the proper selection of the precursor.

2.5.1. Sol-gel process parameters affecting properties of TiO_2

There are various parameters that influence the size and properties of the TiO_2 particles produced via the sol-gel process. To get TiO_2 particles with desirable properties, the parameters that influence hydrolysis and condensation reactions of the sol-gel process should be controlled. It has been established that some parameters are more important than others. The parameters include pH, nature and concentration of the catalyst, water/precursor molar ratio, reaction temperature, precursor concentration, type of solvent and type of precursor [61, 62].

2.5.1.1. Precursor concentration

Particle size increases with increasing precursor concentration due to enhanced coagulation and sintering resulting from the large concentration of TiO_2 nuclei generated at high TTIP precursor concentrations [63]. Increase in precursor concentration increases the crystallinity of the anatase, and enhances transformation from anatase to rutile [64].

2.5.1.2. Water content

The amount of water is a crucial parameter in controlling the hydrolysis reaction. Xiaobo [31] reported that the development of Ti-O-Ti chains through alkoxylation is favored when the content of water is low, with low hydrolysis rates and excess titanium alkoxide in the

reaction mixture. The amount of water should not be too low otherwise the hydrolysis of the alkoxides with water will be incomplete and condensation occurs between the monomers of $(\text{OH})_x\text{Ti}(\text{OR})_{4-x}$ [65]. Other researchers reported that the ratio of water to the alkoxide required for particle formation should be greater than 2.5 as deduced from the equation $R = [\text{H}_2\text{O}]/[\text{TEOT}] > 2.5$ [66]. The largest R value reported was 7 which gave particles with average size of 300 nm. If the amount of water is increased, a stronger nucleophilic reaction between water and alkoxide molecules occurs resulting in more alkoxy groups being substituted by OH groups of water. The monomers obtained then interact with each other to form a three-dimensional network structure. When R is over a critical value, the hydrolysis is more complete and more alkoxides convert to the corresponding metal hydrates, $\text{M}(\text{OH})_z$ which then react with each other to form particle-like polymers [65]. The formation of $\text{Ti}(\text{OH})_4$ is favored by high hydrolysis rates caused by large amounts of water.

According to a study by Yu and Wang [65], the molar ratio of H_2O /alkoxides (R_w) used in the sol-gel process strongly affect the characteristics of the resultant oxides as shown in **Figure 5(a)**. They suggested that the reaction mechanisms for sol-gel conversion depend on R_w used and they came up with three different mechanisms as shown in **Figure 5(b)**. All mechanisms could occur at the same time but there would be a dominant one [65]. Case I: When R_w is less than four ($R_w < 4$), the hydrolysis between alkoxides and water is incomplete hence condensation reaction occurs between the monomers. Case II: When R_w is increased to between two and four ($2 < R_w \leq 4$), stronger nucleophilic reaction between water and alkoxide molecules monomers occurs and a three-dimensional network is formed. Case III: When R_w used is over the critical value the hydrolysis will be complete. The alkoxides will convert to the corresponding metal hydrates. The monomers will react with each other to form particle-like polymers.

2.5.1.3. pH

The pH of the sol-gel system for the preparation of uniform nanoparticles of anatase titania from condensed TiO_2 gel is a key factor for controlling the final particle size and shape of the product [67]. The grain size of the TiO_2 particles generally increases with increase in pH of the sol [68]. When the hydrogen ion concentration is high, the particles grow rapidly to form large grains because the hydrogen ions interfere in the reaction and decrease the nucleation rate. The new nucleus has enough time to grow and aggregate into large TiO_2 particles [69]. Matijevic et al. [70] reported the synthesis of TiO_2 spherical particles of a narrow size by aging a highly acidic solution of titanium tetrachloride at elevated temperatures for 6–47 h. The amount of acid (pH) determines not only the size of the nanoparticles but also the stability of the sol [71].

2.5.1.4. Temperature

The sol-gel temperature is a critical parameter in controlling the properties of the resulting TiO_2 nanoparticles. Vorkapic and Matsoukas [71] studied the effect of the hydrolysis temperature on particle size where they varied the temperature between 0 and 50°C and they found out that low hydrolysis temperatures favored formation of larger particles. When the temperature was increased, the size decreased and reached a minimum in the range 25–50°C. High

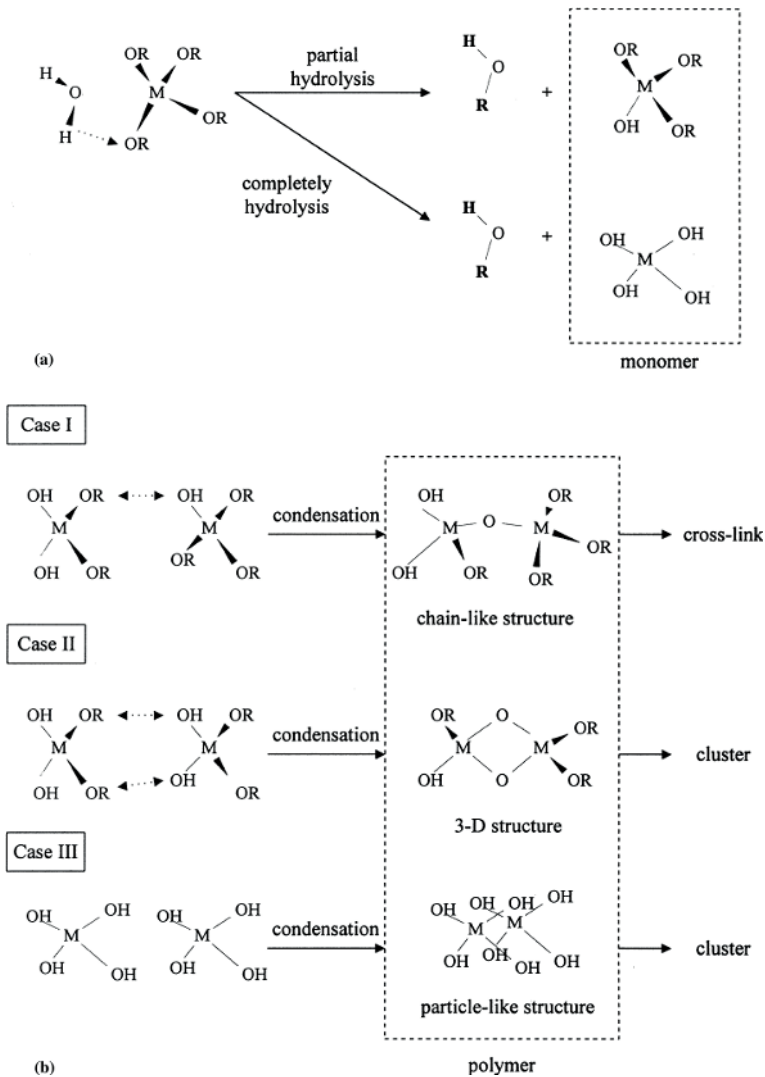

Figure 5. Sol-gel processes with different water contents [65].

temperatures increase the thermal energy of the colloid, decreases viscosity and the dielectric constant of the solvent, thus lowering the electrostatic barrier against aggregation resulting in larger particles [72].

2.5.1.5. Precursor type

Vorkapic and Matsoukas investigated the effect of different alkoxides on the size of the TiO₂ nanoparticles and they found out that at 25°C, the final size decreases with increase in the

length of the alkoxy group [71]. Their results showed that particle size decreased in the order ethoxide > propoxide \geq isopropoxide > butoxide, corresponding to the order of decreasing reactivity of the alkoxide hence the lower hydrolysis rate.

2.5.1.6. Solvent type and concentration

In general, after nucleation, the particles grow by molecular addition or aggregation and this particle growth is affected by the kinds of solvents used because particle interaction potential is different in each solvent. The increase in the amount and molecular weight of the alcohol was found to increase the size of the particles and the smallest size was obtained when no alcohol was used [71]. This is due to the fact that an increase in both concentration and molecular weight leads to a decrease in the dielectric constant of the solvent resulting in decreased stability and enhanced rate of re-aggregation and larger particle size. The formation of TiO_2 from thermal hydrolysis of titanium tetrachloride in water/n-propanol mixtures was investigated by Park et al. [73]. The study showed that when powders were redispersed in various solvents the degree of aggregation increased in the order: methanol > ethanol > propanol suggesting that colloidal destabilization was the primary mechanism by which these alcohols influenced particle size.

In another study by Xu et al. [74], the photocatalytic activity of unsupported TiO_2 gradually increased with increase in the chain of the solvent used in preparation due to the increase in the content of anatase and a decrease in particle size. They found out that when the solvent was changed from methanol to 2-pentanol, the content of anatase increased from 68 to 91% with a decrease in particle size from 11.6 to 10.5 nm. The increase in alcohol concentration in the sol-gel reaction mixture can slow down the hydrolysis rate and the resulting sol would possess a high content of amorphous TiO_2 .

2.6. Template-based methods

Template-assisted synthesis is an easy, cost effective and highly versatile approach to fabricate nanostructures. Whenever microporous or nanoporous materials are utilized as templates, one-dimensional (1D) nanostructures can be integrated by saving a material of decision inside the format's nano-channels. Template-based synthesis is a method in which a nanoporous material is used as the mold and the desired nanotube material is coated on the walls of the mold. There are two approaches for template-based synthesis which are the negative and positive template. The template is then dissolved to get the nanotubes or nanorods. If the material of interest is coated on the inner walls, then it is a negative template-based synthesis. If the material is coated on the outer walls of the template then is a positive template-based synthesis. In the negative template synthesis, if the pores of the mold are entirely filled, then nanorods can be synthesized. The most commonly used template for negative template synthesis is anodic aluminum oxide. Yuan et al. showed the synthesis of TiO_2 nanotubes and nanorods using anodic aluminum oxide as a template [75]. The walls of the template were coated using the hydrolysis method. The anodic aluminum oxide was used as the membrane between deionized water and the $\text{Ti}(\text{OC}_4\text{H}_9)_4$ solution in $\text{C}_4\text{H}_9\text{OH}$ during hydrolysis. The thickness of the nanotubes walls were controlled by varying the concentration of $\text{Ti}(\text{OC}_4\text{H}_9)_4$. Jiang et al. reported the synthesis of TiO_2 nanotubes by immersing anodic aluminum oxide

in an aqueous ammonium hexafluorotitanate solution [76]. Michailowski et al. showed the synthesis of TiO_2 nanotubes via a thermal decomposition process of $\text{Ti}(\text{O}i\text{-Pr})_4$ using anodic aluminum oxide as a template [77]. Correspondingly, Liang et al. revealed the synthesis of TiO_2 nanotubes through atomic layer deposition [78]. Anodic aluminum oxide was utilized as the template, and TiCl_4 was used as the precursor for the atomic layer deposition of TiO_2 .

The atomic layer deposition approach is a highly conformal coating process, and the thickness can be controlled very precisely. Therefore, in this method, the thickness of the walls of the nanotube can be controlled very precisely. The entire undesired TiO_2 deposited layer on the top surface of the template is eliminated by mechanical polishing. Hoyer showed the synthesis of TiO_2 nanotubes using positive template [77]. In this approach, TiO_2 was deposited on poly(methyl methacrylate) nanorods arrays by the electrochemical deposition procedure. The nanorods were selectively etched to form TiO_2 nanotubes. The nanorods were, however, fabricated using an anodic aluminum oxide template. Likewise, TiO_2 nanotubes were synthesized using electro-spun poly(L-lactide) fibers as a positive template [79]. Jung et al. confirmed the synthesis of double wall TiO_2 nanotubes which were fabricated by condensing $\text{Ti}(\text{O}i\text{-Pr})_4$ precursors onto both surfaces of the self-assembled organogel tubes [80]. In comparison to negative template-based synthesis, the positive-based template has a better control on the smoothness of the inner and outer wall. The advantage of this template-based synthesis is that the dimensions of the nanotubes can be controlled by controlling the pore dimensions of the template. The disadvantages of this technique are that the fabrication process is relatively more complicated, and the nanotube morphology can be destroyed during fabrication steps such as mechanical polishing.

Nanoporous media typically used as templates for 1D nanostructure fabrication include track-etch membranes, which are commonly made from polymers including poly(carbonate), poly(ethylene terephthalate) or poly(imide) [81, 82] and anodized aluminum oxide (AAO), which can be purchased commercially or fabricated using a well-known anodization process [81–84]. In addition to nanoporous materials, templates can also be fabricated using lithographic techniques. The use of AAO templates is especially attractive because of its simple, low cost and highly controllable fabrication method. Vertically orientated CrO_2 nanorods arrays were obtained through atmospheric-pressure CVD assisted by AAO templates and were etched to form nanotubes. Such ordered nanorods within an AAO template may be significantly applied in ultrahigh-density perpendicular magnetic recording devices.

2.7. Electrochemical anodization

Electro-anodization is an electrolytic process used to grow the oxide layer on the surface of the metal. When anodizing, the metal to be treated forms an anode electrode of an electric circuit. Anodization alters the microscopic texture of the surface and the crystal structure of the metal close to the surface.

Metal anodization has been greatly used in industry as a surface treatment technique to render materials with resistance against uncontrolled oxidation, abrasion and corrosion. Anodizing increases corrosion resistance of oxide film over a metallic surface and wears resistance, and also improves adhesion for paint primers and glues than bare metal [85]. Although this technique has been developed for a long time, it was until 1990s that researchers discovered that

highly ordered nanoporous structures can be achieved by varying anodization conditions including electrolyte composition and concentration, temperature, as well as anodization voltage [86]. The dense and uniform layer of anodized oxide inhibits ionic conductivity, thus they can be regarded as barrier oxides to effectively protect the metal from further corrosion. On top of that, the anodized oxide film can improve the surface properties of metal, such as wearing, galling and dielectric layer.

Among all metals that can be anodized, aluminum and titanium can be anodized into nanoporous structures with well controlled depth, diameter and pitch. The working metal is set as anode to oxidize during the electrochemical process and cathode can be any electronic conductor mainly platinum, which would not react in the anodizing bath. The electrolyte is chosen according to its higher growing rate of the oxide compared to its dissolution rate or by the insolubility with the anodized metal. As the reaction progresses the metal at positive terminal withdraws electrons, by so doing allowing the ions on the metal surface to react with water in the electrolyte to form a dense oxide layer. Later the electrons return back to the electrolyte where they react with hydrogen ions to form hydrogen gas. When metals are exposed to sufficient anodic voltage supply in an electrochemical configuration, an oxidation reaction takes place ($M \rightarrow M^{n+} + ne^{-}$). Depending mainly on the electrolyte and the anodization parameters, there are essentially three possibilities for reactions to occur:

1. The M^{n+} ions are solvated in the electrolyte, that is, the metal is continuously dissolved and corrosion, or electropolishing of the metal is observed.
2. The M^{n+} ions form react with O^{2-} provided by H_2O in the electrolyte and form a compact oxide layer (MO), if MO is not stable in the electrolyte.
3. After some time during anodization process, completion between solvatization and oxide formation is established, which results to porous oxide layer.

Many properties of these transition metal anodic oxides become more and more important when the possibilities on a micro or nano scale are explored. Anodic oxide films, with the inherent nanoporous structure, exhibit high surface area, and short solid-state diffusion path for catalysis, electrochemical devices and energy applications. The other advantage of the anodic oxide micro/nano structures is that, the fabrications are achieved by chemical or electrochemical processes that are relatively simple and cost effective. The morphologies of anodic oxides include powders, rods, wires and tubes. Materials ranging from Al, Ti, Zr, W to Ta have all been investigated to form self-assembly nanotubes structures [87]. Among these transition metals oxide nanotubes, anodic titanium oxide (ATO) and anodic aluminum oxide (AAO) are among the most widely studied for their functional properties.

2.7.1. Mechanism of growth of the TiO_2 nanotubes

This section reviews the growth mechanism of titanium dioxide nanotubes (TNTs) by electrochemical anodization technique in fluoride-containing electrolyte solution. The formation of TNTs in acidic electrolyte conditions containing fluoride ions are generally agreed to form in the field assisted oxidation and dissolution of formed titanium oxide surface. This process involves two vital steps that occur simultaneously, the formation of titanium oxide and dissolution of the oxide. The process can be explained by the following reactions:



This process usually takes place in a two electrode setup, where titanium film serves as anode and platinum as cathode. The anode Ti is immersed into electrolyte solution, ionic species such as OH⁻ and F⁻ are adsorbed on the surface. The growth of anodic oxide layer depends on the field-aided transport of mobile ions through the oxide. Depending on the speed of the ionic species (Ti⁴⁺ and O²⁻), the growth of the new oxide proceeds at the interface between the metal and oxide or at the interface between oxide and electrolyte (compact anodic oxide layers may grow at either interfaces, but under most conditions oxide grows at the metal-oxide interface). The growth of an anodic oxide layer is determined by the field-aided transport of mobile ions through the oxide.

The presence of fluorides in the electrolyte strongly affects the anodization process, as fluorides form water soluble [TiF₆]²⁻ species. On one hand, complexation occurs with Ti⁴⁺ ions that are ejected at the oxide-electrolyte interface [after migration through the oxide film; Eq. (6)]:



And on the other hand by chemical attack of the formed TiO₂ Eq. (5).

Depending on the fluoride concentration, three very different electrochemical characteristics can be obtained [87]. If the fluoride content is very low (≤0.05 wt%), a characteristic as in the fluoride ion-free case is observed; that is, after anodizing the material to a voltage above up, a stable compact oxide layer is formed. If the fluoride concentration is high (~1 wt%), no oxide formation can be observed, as all the Ti⁴⁺ formed immediately reacts with the abundant fluoride to form soluble [TiF₆]²⁻ (the reaction may then be controlled by diffusion of [TiF₆]²⁻ from the surface, and electro polishing of the sample occurs).

For intermediate fluoride concentrations, a competition between oxide formation and Ti⁴⁺ solvation takes place and porous oxide or nanotube formation can be observed. A typical I-t curve for conditions that leads to nanotubes formation. The curve shows three stages: in the initial stage of anodization, the curve essentially follows the fluoride-free case and if samples are removed from the electrolyte, a compact oxide layer is present. In stage II, a current increase occurs, and irregular nanoscale pores are initially formed that penetrate the initial compact oxide (the current increases as the reactive area increases). In stage III, the current drops again as a regular nanoporous structure or nanotube layer forms. The penetrated compact oxide (random pore layer and initiation layer) often remains as remnants that are frequently found after anodization on the tube tops [87, 88]. Various efforts have been directed toward removing these layers [89, 90], as they interfere with any transport process into the tubes or hamper the exploitation of tube size effects [91, 92]. After self-organization occurred, the tube growth continues at steady current densities. For extended anodization, the growth may be determined by diffusional effects [93] and thus agitation (and gravity effects) and viscosity may become important. The length of the TNTs is determined by the dynamic equilibrium between the oxide formation and chemical dissolution of the oxide. Water oxidation at the anode results

in the formation of oxygen and the hydrogen formation at the cathode as shown in Eq. (7). Meanwhile, a small amount of hydrogen ions from the electrolyte is reduced to form hydrogen bubbles at the cathode shown in Eq. (8). These bubbles can be clearly observed at the cathode during the experiments, while there is no apparent observations of oxygen bubbles flowing up toward the electrolyte surface at the anode electrode. It is possible that there might be only about 2% amount of water volume resulting to no obvious phenomenon.



3. Conclusion

In this review, we summarized some of the progress in the synthesis of titanium dioxide nanoparticles. A lot of effort has been put recently in the synthesis of nanostructured TiO_2 with different properties and applications. The modifications of the nanoparticles brought some new properties resulting in new applications. From the synthetic methods that have been reviewed, it is clear that there is still a potential to come up with nanostructured TiO_2 particles with different properties through the modifications of the existing methods. Although the nanoparticles with new properties might be more efficient, their toxicity should be assessed.

Acknowledgements

The authors are grateful for the financial support from the National Research Foundation (South Africa).

Author details

Pardon Nyamukamba^{1*}, Omobola Okoh¹, Henry Mungondori¹, Raymond Taziwa² and Simcelile Zinya²

*Address all correspondence to: pnyamukamba@ufh.ac.za

1 Chemistry Department, University of Fort Hare, Alice, South Africa

2 Fort Hare Institute of Technology, University of Fort Hare, Alice, South Africa

References

- [1] Byranvand MM, Kharat AN, Fatholahi L, Beiranvan ZMA. Review on synthesis of Nano- TiO_2 via different methods. *Journal of Nanostructures*. 2013;3:1-9

- [2] Banfield JF, Zhang H. Nanoparticles in the environment. *Reviews in Mineralogy and Geochemistry*. 2001;**44**(1):1-58
- [3] Brock T, Groteklaes M, Mischke. *European Coatings Handbook*. Hannover, Germany: Vincent Verlag; 2000
- [4] Beydoun D, Amal R, Low G. Role of nanoparticles in photocatalysis. *Journal of Nanoparticle Research*. 1999;**1**:439
- [5] Adachi M, Murata Y, Okada T, Yoshikawa S. Formation of titania nanotubes and applications for dye-sensitized solar cells. *Journal of the Electrochemical Society*. 2003;**150**(8): G488-G493
- [6] Halary-Wagner E, Wagner F, Hoffmann P. Titanium Dioxide Thin Film Deposition on Polymer Substrates by Light Induced Chemical Vapour Deposition. Submitted to Euro-CVD 14, Paris, France; 2003
- [7] Macák M. Growth of anodic self-organized titanium dioxide nanotube layers [Ph.D. thesis]. University Erlangen-Nürnberg-Germany; 2008
- [8] Chen X, Mao SS. Titanium dioxide nanomaterials: Synthesis, properties, modifications, and applications. *Chemical Reviews*. 2007;**107**:2891-2959
- [9] Pratsinis SE. History of manufacture of fine particles in high-temperature aerosol reactors. In: Ensor DS, editor. *Aerosol Science and Technology: History and Reviews*, 1st ed. RTI International, Research Triangle Park; 2011
- [10] Chabra V, Pillai V, Mishra BK, Morrone A, Shah DO. Synthesis, characterization, and properties of microemulsion-mediated nanophase TiO₂ particles. *Langmuir*. 1995;**11**:3307
- [11] Seifried S, Winterer M, Hahn H. Nanocrystalline Titania films and particles by chemical vapor synthesis. *Chemical Vapour Deposition*. 2000;**6**(5):239-244
- [12] Oh SM, Ishigaki T. Preparation of pure rutile and anatase TiO₂ nanopowders using RF thermal plasma. *Thin Solid Films*. 2004;**457**:186-191
- [13] Gablenz S, Voltske D, Abicht HP, Neumann-Zoralek J. Preparation of fine TiO₂ powders via spray hydrolysis of titanium tetraisopropoxide. *Journal of Materials Science Letters*. 1998;**17**(7):537-539
- [14] Boccacini A, Zhitomirsky I. Application of electrophoretic and electrolytic deposition techniques in ceramic processing. *Current Opinion in Solid State and Material Science*. 2002;**6**:257-260
- [15] Besra L, Liu M. A review on fundamentals and applications of electrophoretic deposition (EPD). *Progress in Materials Science*. 2007;**52**(1):1-61
- [16] Nyongesa F, Aduda B. Electrophoretic deposition of titanium dioxide thin films for photocatalytic water purification systems. *Advances in Materials*. 2017;**6**(4):31-37. DOI: 10.11648/j.am.20170604.11
- [17] Narayan MR, Raturi A. Deposition and characterisation of titanium dioxide films formed by electrophoretic deposition. *Journal of Materials Engineering Innovation*. 2012;**3**(1):17-31

- [18] Cabanas-Polo S, Boccaccini A. Electrophoretic deposition of nanoscale TiO₂: Technology and applications. *Journal of the European Ceramic Society*. 2015;**36**:265-283. DOI: 10.1016/j.jeurceramsoc.2015.05.030
- [19] Ma J, Wang C, Peng KW. Electrophoretic deposition of porous hydroxyapatite scaffold. *Biomaterials*. 2003;**24**:3505-3510
- [20] Put S, Biest O, Anne G, Vleugels J. Microstructural engineering of FGMs by electrophoretic deposition. *Journal of Material Processing Technology*. 2004;**143-144**:572-577
- [21] Xue Z, Zhang W, Yin X, Cheng Y, Wang L, Liu B. Enhanced conversion efficiency of flexible dye-sensitized solar cells by optimization of the nanoparticle size with an electrophoretic deposition technique. *RSC Advances*. 2012;**2**:7074-7080
- [22] Miyasaka T, Kijitori Y. Low-temperature fabrication of dye-sensitized plastic electrodes by electrophoretic preparation of mesoporous TiO₂ layers. *Journal of Electrochemical Society*. 2004;**151**(11):A1767-A1773
- [23] Benerkhal N. Innovations in Electrophoretic Deposition of Nanotitania-Based Photoanodes for Use in Dyesensitized Solar Cells [PhD Thesis]. McGill University; 2013
- [24] Nguu J, Nyongesa F, Musembi R, Aduda B. Electrophoretic deposition and characterization of TiO₂/Nb₂O₅ composite thin films for dye sensitized solar cells. *Journal of Materials Physics and Chemistry*. 2018;**6**(1):1-8
- [25] Dhiflaoui H, Khelifi K, Cheikhlarbi AB. Effect of deposition parameters on electrophoretically deposited TiO₂. *Journal of Material Sciences*. 2016;**4**(3):7-15
- [26] Keskinen H. Synthesis of Nanoparticles and Preparation of Deposits by Liquid Flame Spray [DTech Thesis]. Tampere: Tampere University of Technology; 2007
- [27] Kozhukharov S, Tchaoushev S. Spray pyrolysis equipment for various applications. *Journal of Chemical Technology and Metallurgy*. 2013;**48**(1):111-118
- [28] Kozhukharov S, Tchaoushev S. Perspectives for development and industrial application of spray pyrolysis method. *Annual Proceeds. "Angel Kanchev" University of Ruse*. 2011;**50**(9):46-50
- [29] Wegner K, Schimmoeller B, Thiebant B, Fernandez C, Rao TN. Pilot plants for industrial nanoparticle production by flame spray pyrolysis. *Kona Powder and Particle Journal*. 2011;**29**:251-265
- [30] Taziwa T, Meyer E. Fabrication of TiO₂ Nanoparticles and Thin Films by Ultrasonic Spray Pyrolysis: Design and Optimization. ISBN 978-953-51-3312-4, Print ISBN 978-953-51-3311-7
- [31] Xiaobo C. Titanium dioxide nanomaterials and their energy applications. *Chinese Journal of Catalysis*. 2009;**30**:839-851
- [32] Varghese OK, Gong DW, Paulose M, Grimes CA, Dickey EC. Crystallization and high temperature structural stability of titanium oxide nanotube arrays. *Journal of Materials Research*. 2003;**18**:156

- [33] Kim H, Noh K, Choi C, Khamwannah J, Villwock D, Jin S. Extreme superomniphobicity of multiwalled 8 nm TiO₂ nanotubes. *Langmuir*. 2011;**27**:10191-10196
- [34] Malekshahi Byranvand M, Nemati Kharat A, Fatholahi L, Malekshahi Beiranvand Z. A review on synthesis of nano-TiO₂ via different methods. *Journal of Nanostructures*. 2013; **3**(1):1-9
- [35] Yu JC, Yu JG, Ho W, Zhang LZ. Preparation of highly photocatalytic active nano-sized TiO₂ particles via ultrasonic irradiation. *Chemical Communications*. 2001:1942-1943. 10.1039/B105471F
- [36] Zhu Y, Chen F. Microwave-assisted preparation of inorganic nanostructures in liquid phase. *Chemical Reviews*. 2014;**114**(12):6462-6555
- [37] Collins MJ Jr. Future trends in microwave synthesis. *Future Medicinal Chemistry*. 2010; **2**(2):151-155
- [38] Jacob J, Chia LHL, Boey FYC. Thermal and nonthermal interaction of microwave-radiation with materials. *Journal of Materials Science*. 1995;**30**:5321
- [39] de la Hoz A, Díaz-Ortiz Á, Moreno A. Microwaves in organic synthesis. Thermal and non-thermal microwave effects. *Chemical Society Reviews*. 2005;**34**:164
- [40] Gressel-Michel E, Chaumont D, Stuerger D. From a microwave flash-synthesized TiO₂ colloidal suspension to TiO₂ thin films. *Journal of Colloid and Interface Science*. 2005;**285**: 674-679
- [41] Corradi AB, Bondioli F, Foche B, Ferrari AM, Grippo C, Mariani E, Villa C. Conventional and microwave-hydrothermal synthesis of TiO₂ nanopowders. *Journal of the American Ceramic Society*. 2005;**88**(9):2639-2641
- [42] Baldassari S, Komarneni S, Mariani E, Villa C. Rapid microwave-hydrothermal synthesis of anatase form of titanium dioxide. *Journal of the American Ceramic Society*. 2005;**88**:3238
- [43] Reis KP, Ramanan A, Whittingham MS. Hydrothermal synthesis of sodium tungstates. *Chemistry of Materials*. 1990;**2**:219-221
- [44] Feng XJ, Zhai J, Jiang L. The fabrication and switchable superhydrophobicity of TiO₂ nanorod films. *Angewandte Chemie International Edition*. 2005;**44**(32):5115-5118
- [45] Kim CS, Moon BK, Park JH, Choi BC, Seo HJ. Solvothermal synthesis of nanocrystalline TiO₂ in toluene with surfactant. *Journal of Crystal Growth*. 2003;**257**:309
- [46] Christensen AN. Hydrothermal preparation of some oxides and some oxide hydroxides at temperatures up to 900°C and pressures up to 80 kb. *Materials Research Bulletin*. 1971;**6**:691-697
- [47] Zapf PJ, Hammond RP, Haushalter RC, Zubieta J. Variations on a one-dimensional theme: The hydrothermal syntheses of inorganic/organic composite solids of the iron molybdate family. *Chemistry of Materials*. 1998;**10**:1366-1373. DOI: 10.1021/cm9707667

- [48] Zheng W, Liu R, Peng D, Meng G. Hydrothermal synthesis of LaFeO₃ under carbonate containing medium. *Materials Letters*. 2000;**43**:19-22
- [49] Song H, Rioux RM, Hoefelmeyer JD, Komor R, Niesz K, Grass M, Yang P, Somorjai GA. Hydrothermal growth of mesoporous SBA-15 silica in the presence of PVP-stabilized Pt nanoparticles: Synthesis, characterization, and catalytic properties. *Journal of American Chemical Society*. 2006;**128**:3027-3037. DOI: 10.1021/ja057383r
- [50] Albu SP, Ghicov A, Aldabergenova S, Drechsel P, LeClere D, Thompson GE, Macak JM, Schmuki P. Formation of double-walled TiO₂ nanotubes and robust anatase membranes communication. *Advanced Materials*. 2008;**20**:4135
- [51] Loryuenyong V, Angamnuaysiri K, Sukcharoenpong J, Suwannasri A. Sol-gel template synthesis and photocatalytic behavior of anatase titania nanoparticles. *ScienceAsia*. 2012;**38**(3):301-306
- [52] Yu XF, Lu YX, Wlodarski W, Kandasamy S, Kalantar-Zadeh K. Fabrication of nanostructured TiO₂ by anodization: A comparison between electrolytes and substrates. *Sensors and Actuators B*. 2008;**130**(1):25-31
- [53] Masuda H, Yamada H, Satoh M, Asoh H, Nakao M, Tamamura T. Highly ordered nano-channel-array architecture in anodic alumina. *Applied Physics Letters*. 1997;**71**:2770-2772. DOI: 10.1063/1.120128
- [54] Liu N, Chen X, Zhang J, Schwank JW. A review on TiO₂-based nanotubes synthesized via hydrothermal method: Formation mechanism, structure modification, and photocatalytic applications. *Catalysis Today*. 2014;**225**:34-51. DOI: 10.1016/j.cattod.2013.10.090
- [55] Stride JA, Tuong NT. Controlled synthesis of titanium dioxide nanostructures. *Solid State Phenomena*. 2010;**162**:261-294. ISSN 1662-9779
- [56] Attar AS, Ghamsari MS, Hajiesmaeilbaigi F, Mirdamadi S, Katagiri K, Baetzold RC. *Journal of the American Chemical Society*. 1981;**103**:6116
- [57] Oskam G, Nellore A, Penn RL, Searson PC. The growth kinetics of TiO₂ nanoparticles from titanium (IV) alkoxide at high water/titanium ratio. *Journal of Physical Chemistry B*. 2003;**107**:1734. DOI: 10.1021/jp021237f
- [58] Mehrotra RC, Singh A. Recent trends in metal alkoxide chemistry. *Progress in Inorganic Chemistry*. 1997;**46**:239-454
- [59] Livage J, Henry M, Sanchez C. Sol-gel chemistry of transition metal oxides. *Progress in Solid State Chemistry*. 1988;**18**:259-341
- [60] Ting KT, Yi SL, Yi JC, Hsin CA. Review of photocatalysts prepared by sol-gel method for VOCs removal. *International Journal of Molecular Sciences*. 2010;**11**:2336-2361. DOI: 10.3390/ijms11062336
- [61] Ding X, Qi Z, He Y. Effect of hydrolysis water on the preparation of nano-crystalline titania powders via a sol-gel process. *Journal of Materials Science Letters*. 1995;**14**(1):21-22. DOI: 10.1007/BF02565273

- [62] Arroyo R, Rodriquez R, Salinas P. Master behaviour for gelation in a sol-gel process under different temperature and pH conditions. *Journal of Non-Crystalline Solids*. 1993; **163**(1):90-96
- [63] Jang HD, Jeong J. The effect of temperature on particle size in gas-phase production of TiO₂. *Aerosol Science and Technology*. 1995; **23**:553-560
- [64] Kim CS, Nakaso K, Xia B, Okuyama K, Shimada M. A new observation on the phase transformation of TiO₂ nanoparticles produced by a CVD method. *Aerosol Science and Technology*. 2005; **39**:104-112. DOI: 10.1080/027868290906986
- [65] Yu HF, Wang SM. Effects of water content and pH on gel-derived TiO₂-SiO₂. *Journal of Non-Crystalline Solids*. 2000; **261**:260-267
- [66] Barringer EA, Bowen HK. Formation, packing and sintering of monodispersed TiO₂ powders. *Journal of the American Ceramic Society*. 1982; **65**:199
- [67] Sugimoto T, Okada K, Itoh H. Synthetic of uniform spindle-type titania particles by the gel-sol method. *Journal of Colloid & Interface Science*. 1997; **193**:140
- [68] Jahromi HS, Taghdisian H, Afshar S, Tasharrofi S. Effects of pH and polyethylene glycol on surface morphology of TiO₂ thin film. *Surface & Coatings Technology*. 2009; **203**: 1991-1996
- [69] Chai LY, Yu YF, Zhang G, Peng B, Wei SW. Effect of surfactant on preparation TiO₂ by pyrohydrolysis. *Transaction of Nonferrous Metals Society of China*. 2007; **17**:176-180
- [70] Matijevic E, Budnik M, Meites L. Preparation and mechanism of formation of titanium dioxide hydrosols of narrow size distribution. *Journal of Colloid Interface Science*. 1997; **61**(2):302-311
- [71] Vorkapic D, Matsoukas D. Effect of temperature and alcohols in the preparation of titania nanoparticles from alkoxides. *Journal of the American Ceramic Society*. 1998; **81**:2815-2820
- [72] Moon YT, Park HK, Kim DK, Kim CH. Preparation of monodisperse ZrO₂ by microwave heating of zirconyl chloride solutions. *Journal of the American Ceramic Society*. 1995; **78**:2690-2694
- [73] Park J, Bauer S, Von Der Mark K, Schmuki P. Nanosize and vitality: TiO₂ nanotube diameter directs cell fate. *Nano Letters*. 2007; **7**(6):1686-1691
- [74] Xu Y, Zheng W, Liu W. Enhanced photocatalytic activity of supported TiO₂: Dispersing effect of SiO₂. *Journal of Photochemistry and Photobiology*. 1999; **122**:57-60. DOI: 10.1016/S1010-6030(98)00470-5
- [75] Yuan L, Meng S, Zhou Y, Yue ZJ. Controlled synthesis of anatase TiO₂ nanotube and nanowire arrays via AAO template-based hydrolysis. *Journal of Materials Chemistry A*. 2013; **1**:2552-2557
- [76] Jiang WF, Ling YH, Hao SJ, Li HY, Bai XD, Cang DQ. In situ template synthesis of TiO₂ nanotube array films. *Key Engineering Materials*. 2007; **336-338**:2200-2202

- [77] Michailowski A, AlMawlawi D, Cheng G, Moskovits M. Highly regular anatase nanotubule arrays fabricated in porous anodic templates. *Chemical Physics Letters*. 2001;**349**:1-5
- [78] Liang YC, Wang CC, Kei CC, Hsueh YC, Cho WH, Perng TP. Photocatalysis of Ag-loaded TiO₂ nanotube arrays formed by atomic layer deposition. *The Journal of Physical Chemistry C*. 2011;**115**:9498-9502
- [79] Hoyer P. Semiconductor nanotube formation by a two-step template process. *Advanced Materials*. 1996;**8**:857-859
- [80] Jung H, Kobayashi H, van Bommel KJC, Shinkai S, Shimizu T. Creation of novel helical ribbon and double-layered nanotube TiO₂ structures using an organogel template. *Chemistry of Materials*. 2002;**14**(4):1445-1447
- [81] Baker LA, Jin P, Martin CR. Biomaterials and biotechnologies based on nanotube membranes. *Critical Reviews in Solid State and Materials Sciences*. 2005;**30**:183-205
- [82] Liang Z, Susa AS, Yu A, Caruso F. Nanotubes prepared by layer-by-layer coating of porous membrane templates. *Advanced Materials*. 2003;**15**(21):1849-1853
- [83] Steinhart M, Wehrspohn RB, Gosele U, Wendorff JH. Nanotubes by template wetting: A modular assembly system. *Angewandte Chemie International Edition*. 2004;**43**(11):1334-1344
- [84] Steinhart M, Wendorff JH, Wehrspohn RB. Nanotubes à la carte: Wetting of porous templates. *Chemphyschem*. 2003;**4**(11):1171-1176
- [85] Chen CC, Fang D, Luo Z. Fabrication and characterization of highly-ordered valve-metal oxide nanotubes and their derivative nanostructures. *Reviews in Nanoscience and Nanotechnology*. 2012;**4**(4):229-256
- [86] Beranek R, Hildebrand H, Schmuki P. Self-organized porous titanium oxide prepared in H₂SO₄/HF electrolytes. *Electrochemical and Solid-State Letters*. 2003;**6**(3):B12-B14
- [87] Kim D, Schmidt-Stein F, Hahn R, Schmuki P. Gravity assisted growth of self-organized anodic oxide nanotubes on titanium. *Electrochemistry Communications*. 2008;**10**:1082-1086
- [88] Song YY, Lynch R, Kim D, Roy P, Schmuki P. TiO₂ nanotubes: Efficient suppression of top etching during anodic growth. *Electrochemical and Solid-State Letters*. 2009;**12**(7):C17-C20
- [89] Albu SP, Schmuki P. TiO₂ nanotubes grown in different organic electrolytes: Two-size self-organization, single vs. double-walled tubes, and giant diameters. *Physica Status Solidi (RRL)-Rapid Research Letters*. 2010;**4**(8-9):215-217
- [90] Park KH, Heo SJ, Koak JY, Kim SK, Lee JB, Kim SH, Lim YL. Osseointegration of anodized titanium implants under different current voltages: A rabbit study. *Journal of Oral Rehabilitation*. 2007;**34**(3):517-527

- [91] Albu SP, Ghicov A, Macak JM, Hahn R, Schmuki P. Self-organized, free-standing TiO₂ nanotube membrane for flow-through photocatalytic applications. *Nano Letters*. 2007; 7(5):1286-1289
- [92] Macak JM, Tshchiya H, Ghicov A, Yasuda K, Hahn R, Bauer S, Schmuki P. TiO₂ nanotubes: Self-organized electrochemical formation, properties and applications. *Current Opinion in Solid State and Materials Science*. 2007;11(1-2):3-18
- [93] Yasuda K, Schmuki P. Control of morphology and composition of self-organized zirconium titanate nanotubes formed in (NH₄)₂SO₄/NH₄F electrolytes. *Electrochimica Acta*. 2007;52(12):4053-4061

