

Wind Power: Integrating Wind Turbine Generators (WTG's) with Energy Storage

Septimus van der Linden
BRULIN Associates, LLC
U.S.A.

1. Introduction

Energy Storage is the missing link between wind driven power generation and delivering power in a sustainable manner that can be dispatched at times of high demand from the grid. Transmission systems that cover large territories such as in North America are particularly vulnerable, requires additional dedicated transmission and readily dispatchable backup power systems.

The installed capacity of Wind Turbine Generators (WTG's) in the US and worldwide, while impressive, suffers from a low capacity factor of 30% or less due to the variability and intermittency of wind as the motive force. In 2007 the global installed capacity was 94 GW with a predicted capacity of 136 GW by 2010, 55% would be installed in Europe and 23 % (31 GW) in North America, these numbers could be exceeded, as the US already has over 29 GW installed capacity with 99 GW in planning in the next 10 years.

The demand for electricity has considerable daily and seasonal variations and the maximum demand may only last for a few hours each year. As a result, some power plants are required to operate for short periods each year – an inefficient use of expensive plants. Without any additional storage above the present 2.5%, mainly PHS, of the installed base load in the USA, base loaded plants are being detrimentally cycled at higher frequency and the situation is further exacerbated by the latest growing demand for renewable energy such as wind energy. In the US, this capacity has now reached in excess of 29,000 MW [Fig 1] summarized by the American Wind Energy Association (AWEA) projects; in Canada the current 2800 MW projects under consideration or contract will grow to 7400 MW to meet energy objectives set for 2015.

Installing larger wind farms, to cover the deficiency of a higher capacity factor, results in high costs per delivered kW/hr. This requires continued tax incentives to deliver “green” energy to the consumers. The full capability of the WTG is never realized, as at high wind speeds, some of the wind energy has to be “spilled” to maintain a smooth delivery profile.

Technology improvements have not overcome the “wasted” capacity of these modern marvels except where Hydro or Pumped Hydro Storage (PHS) facilities are utilized. The Hydro power station can compensate for wind variability and intermittency while PHS provides energy storage and delivers power during high demand periods. Wind Energy Storage results in a much higher capacity factor, in effect reducing the cost of delivered kW/hrs., PHS amounts to less than 2.3 % of the current installed 1000 GW generating capacity and will decrease with the increasing addition of wind generation.

Source: Wind Power, Book edited by: S. M. Mueeen,
ISBN 978-953-7619-81-7, pp. 558, June 2010, INTECH, Croatia, downloaded from SCIYO.COM

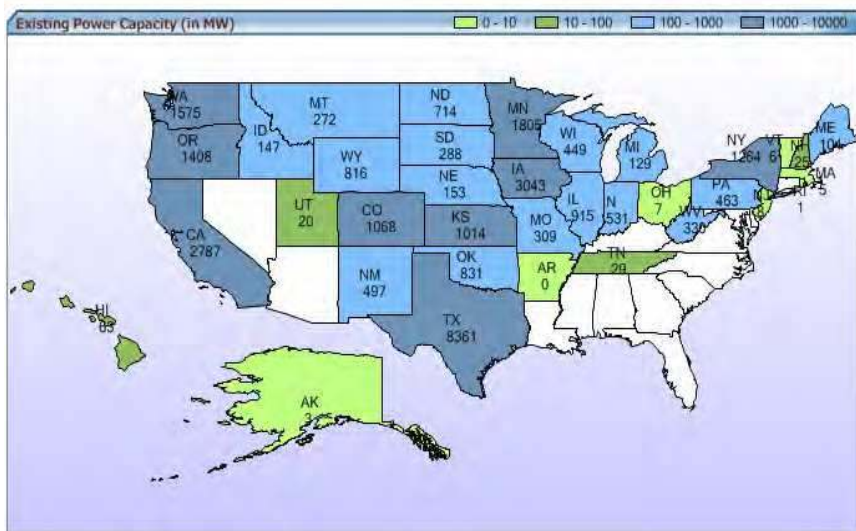

Fig. 1. Installed US Capacity 2009 by State (AWEA)

2. Decoupling energy production from supply

Storage allows energy production to be de-coupled from its supply, self-generated or purchased. WTG's can only receive energy payments for delivered power, requiring the installation of Gas Turbines or cycling of thermal plants to provide capacity that cannot be delivered by wind. The wind generation variation vs. daily demand requirement is illustrated in Fig. 2.

Dependent Wind Power Needs Fossil Power to Accommodate its Variations

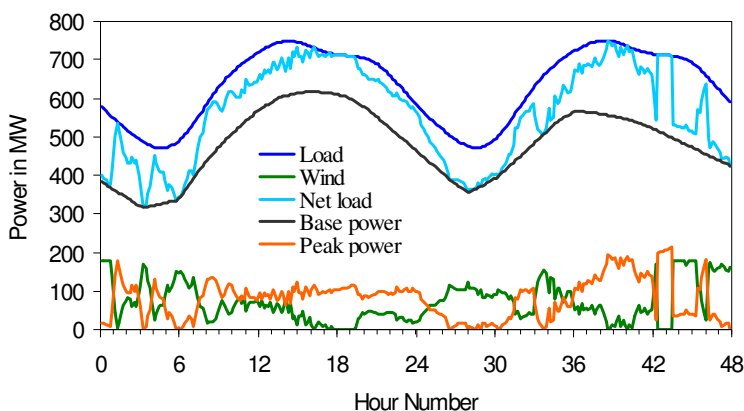

Fig. 2. Wind Energy not available during peak

The problem with the proven bulk energy PHS solution is that the USA or the worldwide installation of WTG's do not have such facilities readily available (some exceptions in Europe), are expensive to construct and difficult to permit in the USA.

A readily available, cost effective alternative bulk-energy storage technology is ready for deployment. The Gas Turbine-Compressed Air Energy Storage (GT-CAES) concept incorporates a standard production GT with CAES technology and so covers a wide range of power production that can be matched to specific storage sites. During excess wind power production or nighttime wind, this power is used to drive air compressors to pump up or pressurize storage facilities such as salt caverns, deep aquifers (depleted natural gas wells) or above ground storage tanks (Pipelines). The stored compressed air is released to an air expander to recover the stored energy. The air to the expansion turbine is pre-heated to 510 oC to 565 oC using the Gas Turbine exhaust energy recovered in a Heat Recovery Unit (HRU). The Gas Turbine low exhaust emissions are reduced further with Selective Catalytic Reduction (SCR) in the HRU. Adiabatic expansion without pre-heating the air before expansion is another possibility.

The electric motors driving the air compressors are large for Bulk Energy Storage facilities, and can absorb large and varying quantities of wind generated power and thus regulate the delivered kW/hrs delivered during peak demand, or store the excess power during low grid demand. Wind as a renewable resource would be able to deliver a larger percentage of "green" capacity with the ancillary power benefits of Storage such as Voltage Regulation, load following, spinning reserve, etc., not a feature of WTG's. Smaller capacity systems of 3 to 30 MW/hrs serve a different purpose for smaller wind farms, primarily in a "smoothing" function of decoupling for power delivery and meeting short duration peak hour generation Fig 3 illustrates the basic concept and motivation for Energy Storage.

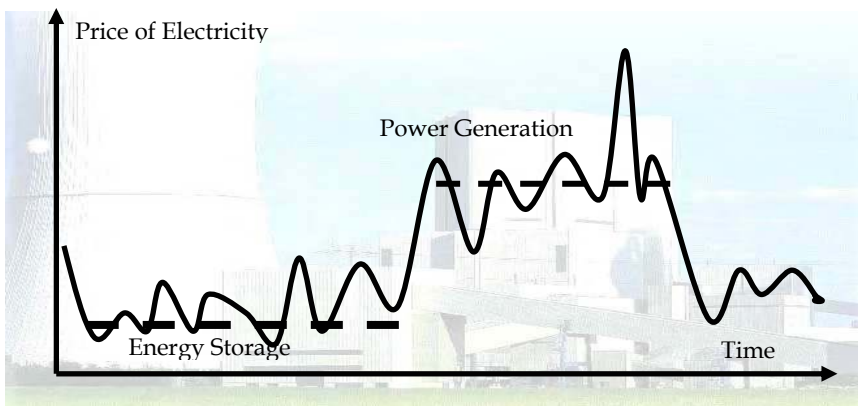

Fig. 3. Motivation for electrical energy storage

The different storage technologies illustrated [Fig 4], can be used in different combinations, to suit the specific needs of the power delivery system, not only in plant output capacity but in response times as well. Response systems such as Flywheels or Flow Batteries (seconds or milliseconds) can be combined with larger bulk systems (minutes and hours) such as CAES or with SSCAES (small surface storage), 60MW/hr systems or larger 135 MW units in several configurations up to 1000 MW or more, depending on storage cavern volume.

By having large-scale electricity storage capacity available over any time, system planners would need to build only sufficient generating capacity to meet average electrical demand rather than peak demands. Fig. 4 shows a multitude of smaller short duration devices with quick response discharge times, this is where a lot of the research and development was focused and does not accommodate large wind contribution. The emphasis today has to be on large scale systems such as pumped hydro and compressed air energy storage to fully integrate the growing installed wind capacity.

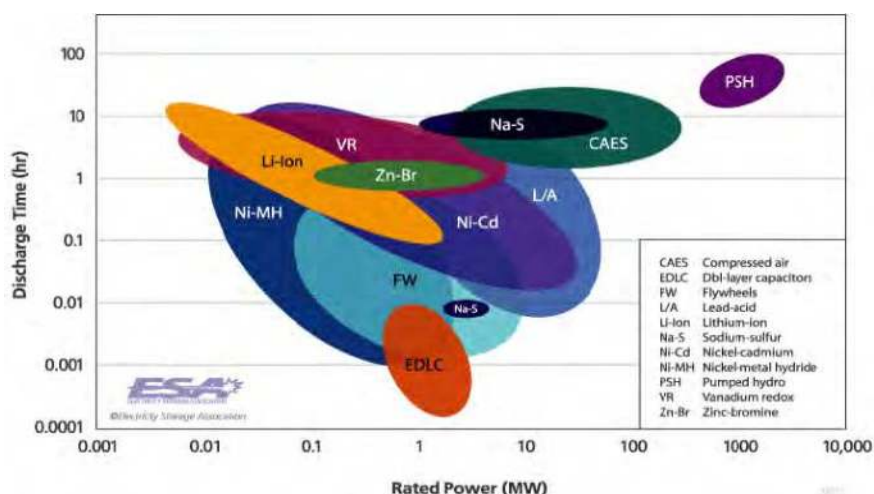

Fig. 4. Operating Regimes for Several Energy Storage Systems (ESA)

In theory, a typical power plant could operate with 40% less generating capacity than would otherwise be required when supported by Energy Storage. This represents considerable financial savings in peaking and intermediate plants. Additional reductions in emissions and capital investment can occur due to the base load generators operating more efficiently at steady state output. The wind energy can be stabilized as well as increased in capacity toward the nameplate rating. Grid instability does lead to regional blackouts. This does open the door for more consideration of Energy Storage. While this is encouraging, there are institutional hurdles to overcome, one of which is the lack of understanding of the value and benefits of Bulk Energy Storage as well as some perceived concepts that simply adding more new power plants and transmission capability will cure blackout problems experienced in recent times in the USA. Storage is probably the better solution!

Storage of electricity (energy) will significantly change the Power Industry for the better: better utilization of resources, better system efficiency, lower emissions, better reliability and security. Geologically suitable identified sites for bulk energy storage using salt domes, hard rock or aquifers can be readily exploited for 20/30 GW capability by 2020 or sooner, a fact not fully recognized by power entities. (van der Linden, Septimus, 2006)

3. How does a CAES system work?

The fundamentals of a Gas Turbine are well understood: atmospheric air is compressed to a higher pressure, fuel is added in a combustion chamber and the hot, high pressure

combustion gas expands through a turbine that provides both the motive power for the compressor (60% or more) and the balance of the power (40% or less) as mechanical energy to drive an electric generator.

In a CAES cycle variation of a standard gas turbine, the compression cycle is separated from the combustion and generation cycle; by using low cost, off-peak or excess electricity, motor driven inter-cooled compressors provide the compressed air held in storage to be released from storage to the modified gas turbine for power generation on demand. In this process, some dramatic changes in the power and economic cycles have occurred. The gas turbine expander absent of its large parasitic load delivers approximately two thirds more power with no increase in fuel consumption. The required compressed air comes at a much lower cost thus enabling lower cost of electricity generation during high demand cycles from other intermediate load systems, in particular the increasing renewable energy mandates and others such as Gas Fired Thermal or Combined Cycle power plants, or even the lower cost Simple Cycle gas turbine power plants. The illustration Fig 5 below will help clarify the CAES concept.

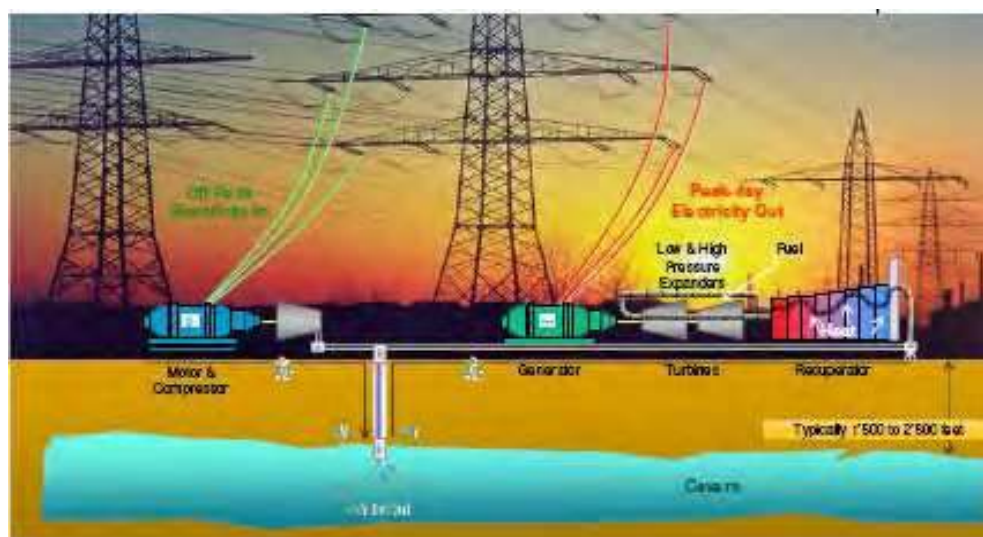

Fig. 5. CAES Concept

The Compressors utilize off peak wind energy to store high pressure air in the storage cavern, which is expanded to generate power when there is a demand during the day; this diurnal wind energy as depicted in Fig. 6 brings maximum wind capability to the grid.

4. CAES technology: storage concepts

Decoupling the Compressor trains from the generating train allows for more flexibility in compression optimization and utilization. Motor driven compressors in 50 MW or lesser increments allow sites and storage volume to best serve the transmission grid needs as well as act as load sinks of 100/200 MW or 300 MW to avoid unnecessary cycling at base loaded plants. The illustration Fig. 7 below captures the decoupling of compression from the power

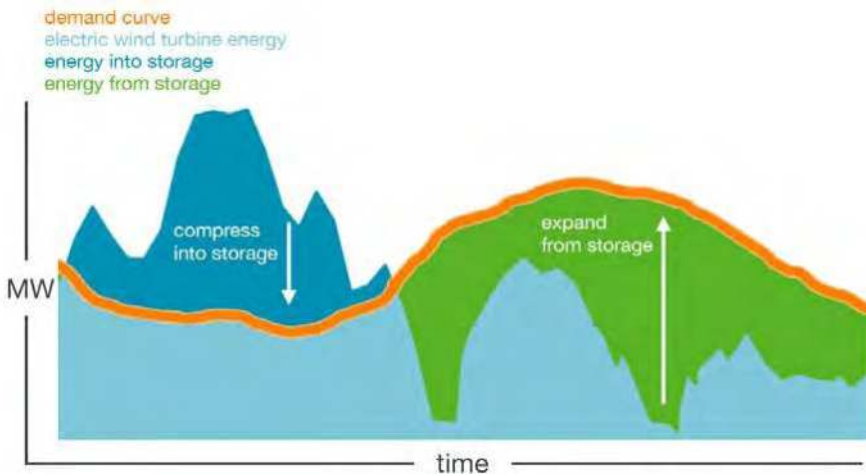

Fig. 6. Meeting the demand curve with stored wind energy (General Compression)

cycle. The Huntorf, Germany and the McIntosh CAES plant compressors are driven by the Generator which operates as a motor during the compression cycle. This limits the flexibility of the plant which today allows compression power to be designed with multiple units to accommodate different rated compression units to balance the wind variability. This optimization allows a larger range of options for different geographical regions with wind variances.

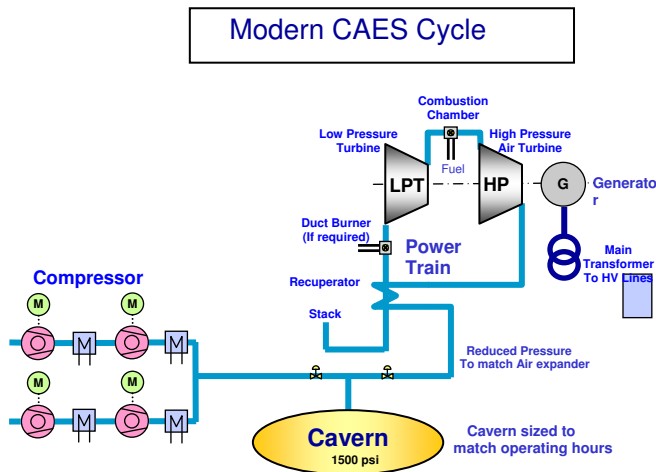

Fig. 7. Decoupling the Compression from Power (Alstom Power)

5. Applications

Stored energy integration into the generation-grid system is best illustrated in (Fig. 8) “Energy Storage Applications on the Grid”. This covers a wide field in every aspect of generation-

transmission and distribution. The ability of the various technologies to react quickly, converting the stored energy back to electricity readily provides three primary functions: Energy Management (hours of duration) load leveling or peak period needs; Bridging Power (seconds or minutes duration) assuring continuity of service, contingency reserves or UPS (Uninterruptible Power Supply); and Power Quality & Reliability (milliseconds or seconds duration) in support of manufacturing facilities, voltage and frequency controls.

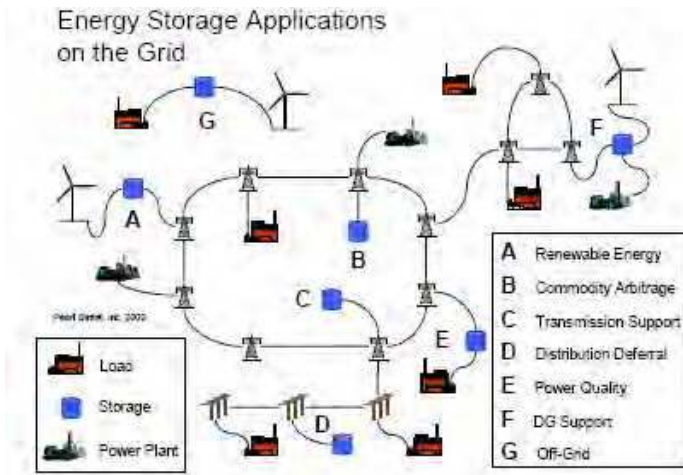

Fig. 8. Energy Storage Applications on the Grid (Pearl Street Inc)

This storage pipe concept could be applied to existing GT/CC plants. Increasing the hot day output 20/25% by injecting the stored air into the combustors with or without humidification (Fig. 9). By applying the humidification concept, the air supply in a CAES plant could reduce the required storage volume by 30% or more, or increase the operating hours by 30% of the specific cavern storage volume. (Nakhmkin, Michael. et al, 2004)

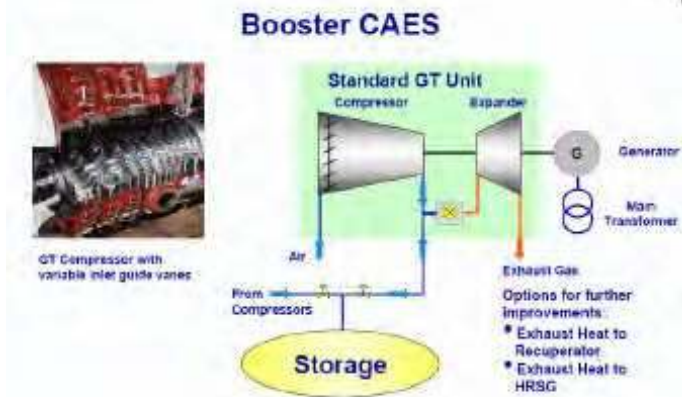

Fig. 9. Air Injection (AI) or booster CAES (Alstom Power)

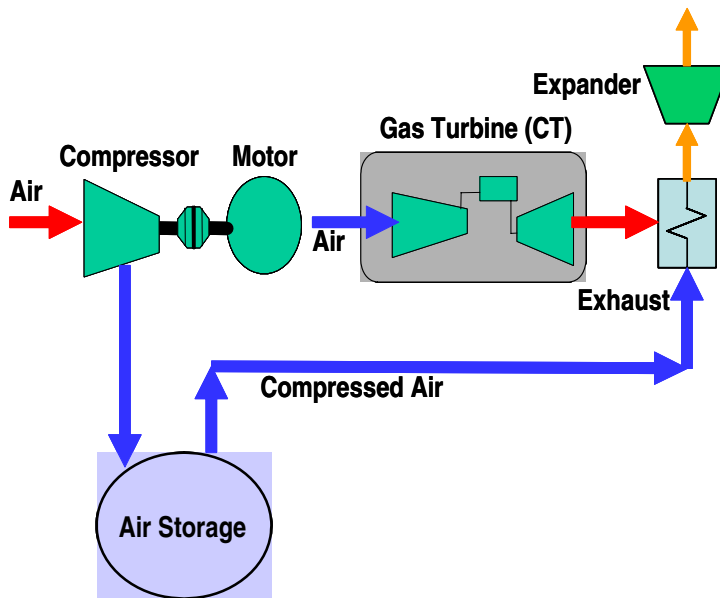

Fig. 10. GT-CAES with production GT (ES & Power LLC.)

In another Hybrid proposed concept, a conventional gas turbine is coupled with storage and a separate unfired air expander for increased flexibility of operation. Using a 180 MW gas turbine, the plant output would exceed 400 MW. (Fig.10). The advanced technology gas turbine with 38% efficiency can be operated independently when the cavern air supply has been drawn down. (Nakhmkin, Michael .et al, 2000)

The separate expander (bottoming cycle) allows stored wind “green” energy to remain clean without products of combustion. Systems of 100 MW supported by a 45 MW Gas Turbine is another of several size options using available production gas turbines rather than specially designed Combustion expanders. The first unit in Huntorf Germany (290 MW) and the first unit in McIntosh Alabama (110MW) have high and low pressure sequential combustors, and inline motor/ generator driven compressors.

Advanced concepts of **Adiabatic** Compression & Expansion, requiring Thermal Energy Storage (TES) have been studied in the US, but more recently in Europe. Such systems would ideally benefit renewable energy systems such as wind, solar and biomass, adding capacity with no premium fuel consumption.

Diabatic CAES plant loses heat from the compression cycle which must be re-generated or added to the compressed air before entering the turbine expansion cycle. Adiabatic CAES will benefit from the thermal energy storage to preheat the stored air which will expand adiabatically through a sliding pressure air turbine, with the added benefit that no CO₂ is generated in the process. Such studies have been completed in Europe with 19 different partners with support and involvement of the European Commission through a research contract. (Bulloch, Chris. et al, 2004)

Thermal storage devices such as the “Cowper” heat storage devices in glass and metallurgical industries were investigated for suitable thermal storage solutions. The study detailed concept sizes of 30, 150 and 300 MW respectively. (Fig.11) From the study it is

concluded that the Dutch electricity market is the most promising for mass storage whereas, less promising, but not ruled out, are Italy, Norway, Sweden France, the Alpine countries with PHS will be exceptions. A series of economic calculations using the national spot market prices for the years 2001 and 2002, and a range of storage capacities, demonstrate that the opportunities are greatest on the Dutch market, with a plant storage capacity of about 3000MWh. The increased fuel costs in 2009 and higher equipment costs for WTG's will change the dynamics for AA-CAES storage/generation.

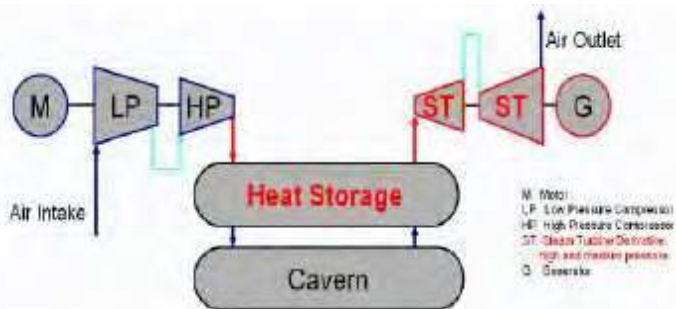

Fig. 11. Advanced Adiabatic CAES Concept (Alstom Power)

Smaller adiabatic systems suitable for isolated Wind Turbine systems where no fuel is added are under development, with utilization of the cold exhaust air to be used for cold storage systems or advanced concepts of “freeze” desalination. Such units of 500 kW and larger are ideal for wind power “smoothing” and distributed generation. The T-CAES 500kW system can produce 3600 liters/hr of fresh water from seawater or saline/brackish water. (Dr. Ben Enis et al., 2006)

The European wind resources and potential are substantial and cover a large area for suitable wind /storage integration, other than the current Hydro plant and PHS already in operation (Fig. 12).

6. Benefits from energy storage

One of the first benefits would be to fully utilize capital assets, considering that the national average for generation capacity factor is 58/60% and transmission 50/52%. Bulk Energy Storage will allow the most efficient units to be fully utilized and allow optimization of the generation mix. The integration of ever increasing renewable sources such as wind with energy storage will bring a larger contribution to the Generation mix. Furthermore, it will avoid the use of inefficient units using premium fuels during peak periods. Needle peaks can be readily met with storage as the distribution level or with current installed “peaker” unit capacity.

The market or economic benefits from Energy Storage can be quantified in four major areas of the electricity supply chain, namely: generation, transmission & distribution, energy services, and renewable energy storage. Projected benefits over a 15 year period for the USA Generation and T&D system could exceed \$100 Billion. Other benefits of Wind Storage are reducing water consumption, CO₂ reduction, Ancillary Service Value and Transmission Value as part of the value chain illustrated in Fig. 13.



Fig. 12. West Europe wind speeds Salt deposits and active salt facilities (Courtesy KBB)

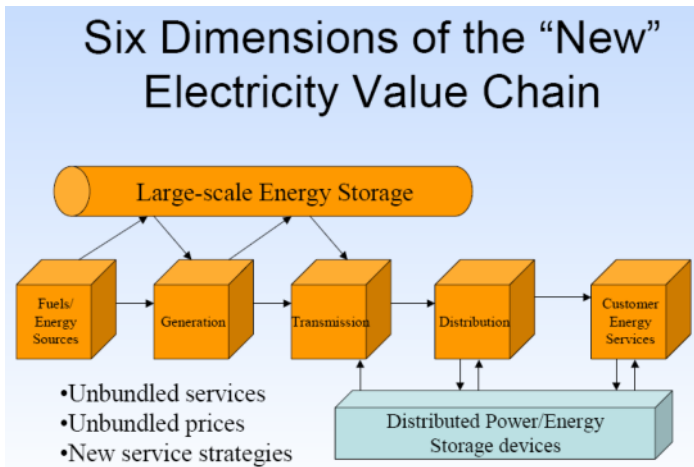

Fig. 13. Large-scale energy storage the “new” Electricity Value Chain 6th dimension (Pearl Street Inc)

Close to 90% of all new U.S. generation capacity added since 2005 has been a combination of natural gas and wind power. The U.S. electric industry faces dramatic transformations as it wrestles with the challenges of the 21st century. The capacity factor of wind requires that 3 MW is installed to displace 1.0 MW of base load coal power, and subsequently backed by gas fired power plant. This is a clarion call for integrating wind with storage technologies increasing the clean mix of renewable and flexible technologies.

Large-scale storage is the 6th dimension in the Electricity value chain which can bring new possibilities to the Utility industry with the growing mandates for 20/30% power generation

from renewable energy in particular wind energy. Note that this does not exclude Distributed Power Energy Storage devices as illustrated in Fig. 13.

7. Water consumption

CAES can increase clean water and more of it: Wind power does not require water, nor does CAES plant. If wind were to provide 20% of our base load electricity by 2030, using Energy Storage technologies, water use by the electricity sector would be cut by 17% in that year. Water is a precious commodity which current fossil plants demand in high quantities for cooling. Many new power plants are using air cooled condensers to conserve water especially in California and Nevada. The Western United States face critical water issues today and renewable energy sources such as concentrated solar power (CSP) now in construction in the high solar radiation areas will have water curtailment for cooling, requiring dry cooling with performance degradation. CAES avoids water use entirely.

8. CO2 reduction

CAES contributes to increasing the CO₂ reduction contributed by wind energy displacing fossil power generation, assuming zero CO₂ emissions for wind whereas Coal would produce 974 Tonnes CO₂/GWe/h and gas fired plant 464 Tonnes CO₂/GWe/h. Increasing wind energy contribution from variable and unpredictable to a dispatchable base load contribution from a capacity factor of 30% to 55 % or higher would significantly mitigate CO₂ issues the power sector faces. The GT/CAES has a heat rate of 4010 kJ/kWh and that of a CC power plant 6500 kJ/kWh (lower heating value) LHV for comparative purposes a 40% improvement over CC and a 64 % improvement an efficient open cycle fast start and load aero-derivative gas turbine used to supplement short coming of wind generation due to variability of wind. The CO₂ reduction of CAES/Wind integration is significant factor in the overall economics considering the CO₂ sequestration programs being promoted.

9. Ancillary service value

The rapid response of a CAES plant capability allows it to provide automatic generation control/regulation in both generation and compression modes. CAES plant provides spinning reserve; a CAES plant with independent compression/generation trains can bring the full generation capacity online in less than 10 minutes. CAES plant can also be considered to be providing quick start or operating reserve with the ability to rapidly shed load while in compression mode, or ramp up while in generation mode. CAES can also provide other ancillary services such as balancing energy and voltage/VAR support.

10. Transmission value

Strategic location of a CAES plant may be valuable from a transmission perspective. When located in an area where wind production is congesting the local transmission lines the CAES plant has the potential to significantly reduce or eliminate congestion and increase grid efficiency by storing the wind energy and releasing it when the wind plants are at a low output and more transmission line capacity is available. The CAES plant has reactive capability in both the generation and compression modes, and when configured with

clutches it can operate in the synchronous condenser mode, to provide and absorb reactive power as needed.

A CAES plant can provide voltage reliability benefit to the transmission grid. Furthermore CAES plant reactive support can be particularly useful when combined with wind plant operation, especially as wind plants have been manufactured with limited reactive capability and installed on weak areas of the grid.

Conventional power plants have more reactive power capability and voltage stability, so when displaced by wind power these abilities are substantially diminished, the negative effects of wind on the transmission grid can be avoided with CAES plant acting as a dynamic Reactive System.

11. Future prospects (developments)

Pumped Hydro has clearly demonstrated the value of Bulk Energy Storage. While these benefits are recognized and utilized, new facilities have languished; projects in development do show promise and opportunities for implementation. The requirement for efficient Clean Coal concepts such as IGCC (gasification) can be enhanced with storage systems to keep the plant at an 80% or better load factor during the off-peak demand periods and deliver the added stored capacity during high demand.

New concepts are being proposed especially with the growing capacity of wind energy, currently backed by tax incentives. However, at 29 GW and projected substantial growth, energy storage and wind energy integration using CAES or Flow Batteries or ganged Flywheels could lead to better economic utilization of a substantial resource operating at below 30% capacity factor – storage could drive this capacity factor to 65% or higher.

Concepts outlined in a paper presented at EESAT 2003 Conference (van der Linden, S., 2003) suggested sub-surface storage using large diameter pipes such as typically used for natural gas transportation. Using a storage complex of 2000 meters of pipe, a system that will provide 60 MW/hrs (15 MW x 4hrs) could enhance power supply at remote wind farms. Introducing such smaller systems will help the industry gain confidence in the value of energy storage, gain operational experience without large expenditure. Smaller capacity systems of 3 to 30 MW/hrs serve a different purpose for smaller wind farms, primarily in a "smoothing" function of decoupling for power delivery and meeting short duration peak hour generation. (Dr. Ben Enis et al., 2006) Other concepts proposed would transmit stored air by pipeline to industrial areas or to bring power to where existing transmission is available. Permitting for new power lines is constantly challenged by environmental groups. Pipelines to transmit the stored energy would help bring more renewable energy into the demand cycle.

The overall principle of operation of the T-CAES system is depicted simply in Figure 14. Note that if the system efficiency is about 50%, then the excess power versus time area is able to deliver either the same excess power in half the time (First part of Figure 14, early time history) or half the excess power for twice the time (Second part of Figure 14, later in the time history).

In order to discuss the performance of the T-CAES system, it is necessary to consider several simplifying assumptions to readily demonstrate trends. First, wind history has 24 identical successive 1-hour periods for each 24-hour day. This assumption produces the most effective volume tank. Second, average power of 46.9% was used compared to the peak power in selecting the shape of the power history sinusoid. Third, the nighttime power

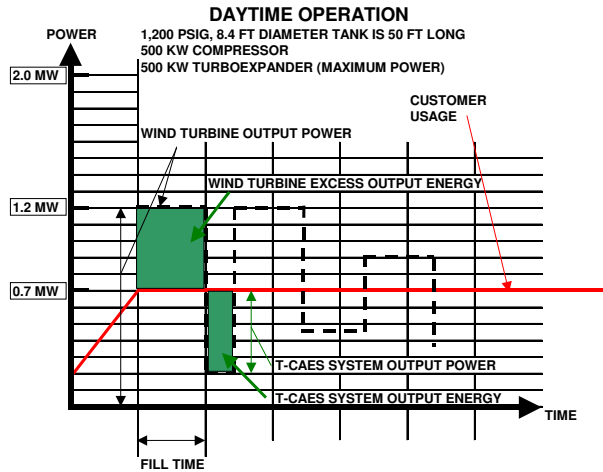

Fig. 14. Overall principal of T-CAES system (Enis Windgen)

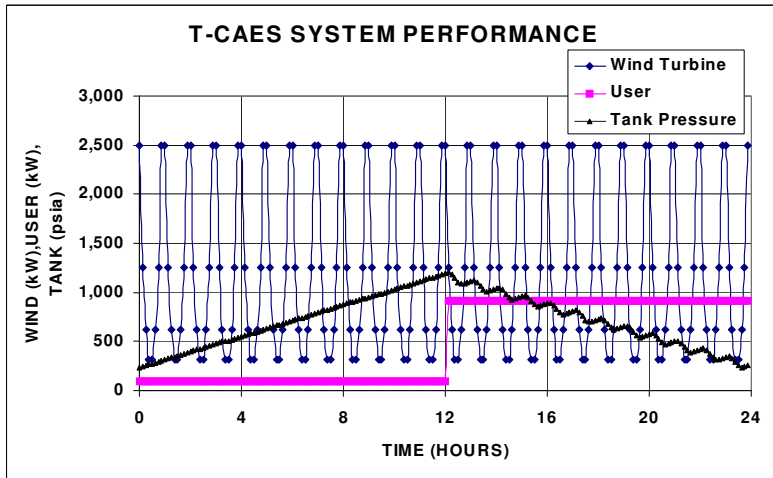

Fig. 15. Electric Power and Storage Histories (Enis Windgen)

requirement is a fraction of the daytime power requirement. Fourth, when daytime and nighttime power usage was excessive for the T-CAES system, a diesel backup was used. (Dr. Ben Enis et al., 2006). Figure 13 shows the wind turbine 2,500-kW power dropping to 312.5-kW and then rising back to 2,500-kW during each 1-hour successive period. The System is delivering 90-kW to the user during the 12-hour period at night and 910-kW to the user during the 12-hour daytime period. The 15.24 m long cylindrical storage tank that is 2.56 m in diameter permits the tank pressure to rise from 16.3 bar at the start and to reach 82.75 bar at the peak, and to return to 17.3 bar-psia at the end of the day. This cycle is therefore ready to repeat itself continuously. If the storage tank is made twice as long, say 30.48 m, then the power lulls can be extended from 1-hour to 2 hours. If there is a set of two 30.48 m long tanks, then there can be a four-hour lull. If there is a wind speed lull that extends

continuously for several days, then neither the T-CAES system nor the underground cavern CAES system can support the user. The diesel system or Gas Turbine is required.

The T-CAES system is amenable to all geological and geographical locations. It falls in the power versus duration region where other energy systems do not apply (Fig. 4). It operates at high power levels (0.5 MW to 10MW) and over many hours. It operates in three modes for different daily scenarios at the same facility: (1) Electrical power mode, (2) Chilled air co-generation and (3) Drives pneumatic equipment and pneumatic tools.

The T-CAES system provides electrical power history “smoothing” so that even smaller wind turbines can provide steady power histories to the user. When there is a differential in price of electricity during the summer daytime and the summer evening, the T-CAES system provides “peak shaving” advantages. The T-CAES system provides backup power when the electrical grid is down or when the wind turbine is idle. The Wind Turbine Generator would be remote at a suitable location, except in some rural area with co-ops or small town Municipalities. Where there are additional services from T-CAES system, such as pneumatic power or chilling then the storage and generation system are co-located with buildings, as the T-CAES system does not burn fossil fuel.

12. US storage geology and +4 wind resources and population density

The two maps Fig 16 & 17 of the US show an interesting perspective where the high wind resources are located and the population density; basically many wind farms are distant from end users with high energy demands, resulting in transmission constraints as well as time of day generation, generally not co-incident with demand. This is also illustrated in Fig 18 as experienced in Europe; imbalances between production and demand. Many small rural towns who depend on their own power generation have opted for wind energy to

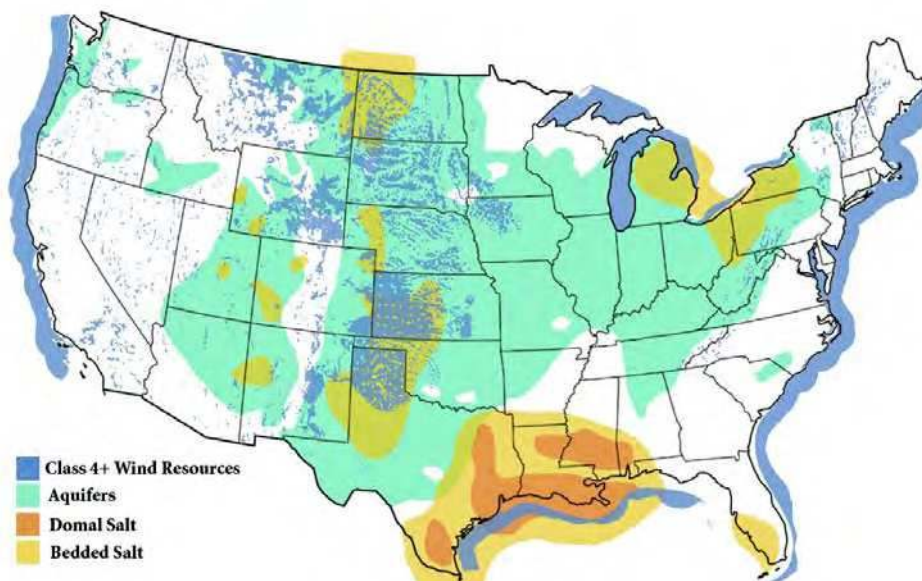

Fig. 16. Areas with geologies favorable for CAES and class 4+ winds

offset increasing fuel costs. These smaller systems may be from one to three WTG's, while helpful do not realize the full benefits of the investment. This also applies to some large schools and Colleges who support the emissions reduction effort in their communities and subsurface storage would be the right answer. The map also indicates that the favorable wind resources in the Midwest have domal and bedded salt as well as aquifers suitable for energy storage. The Iowa Storage Project using a deep saline aquifer is a good example of an Association of Midwest municipalities taking the initiative to collectively harvest their wind resources.

13. Wind resources and population

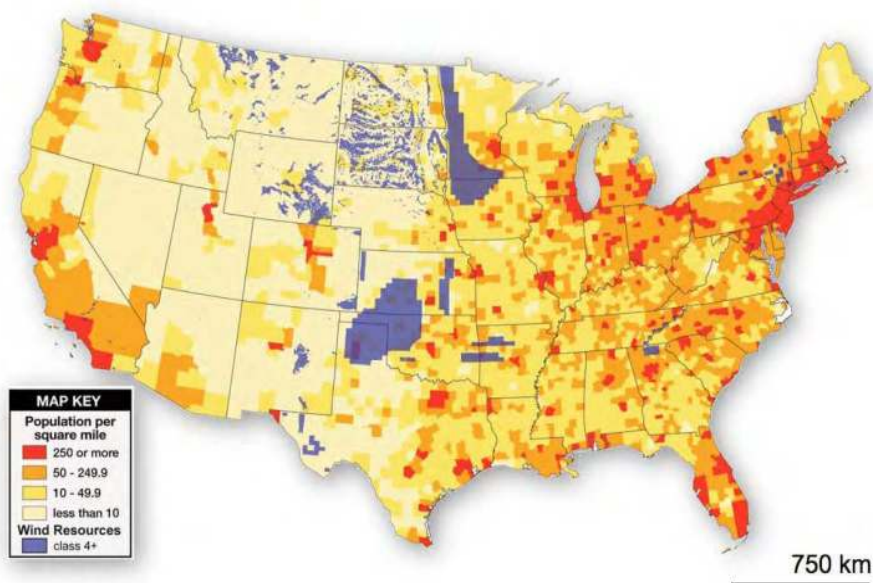

Fig. 17. Onshore wind resources and population density in the continental US (US Census 2000, NREL, 2001/2/6)

14. Wind variability

Wind characteristics vary in different Geographical regions, the chart Fig. 19 provided by California Independent System Operator (CA ISO) illustrates the California Wind Generation in January of 2005, clearly the best generation is at night not serving the high load demand during the day. Storing the wind energy for day time demand would greatly enhance the value of renewable energy with the added benefit of low CO₂ emissions. Other high density wind areas such as in Texas exhibit similar characteristics. The Bonneville Power Authority in the North West does have the benefit of Hydro Power to compensate for the wind variations.

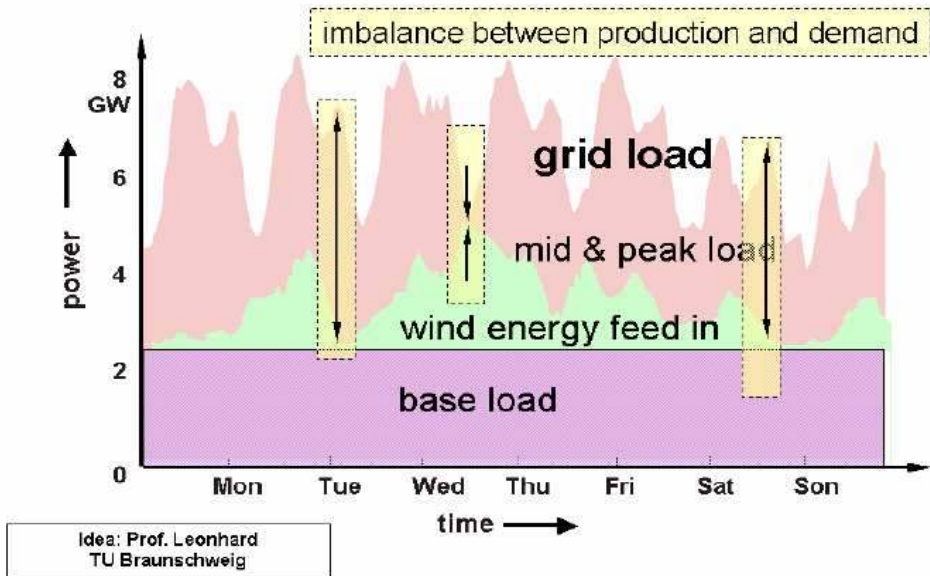

Fig. 18. Imbalances between Wind production and Power demand

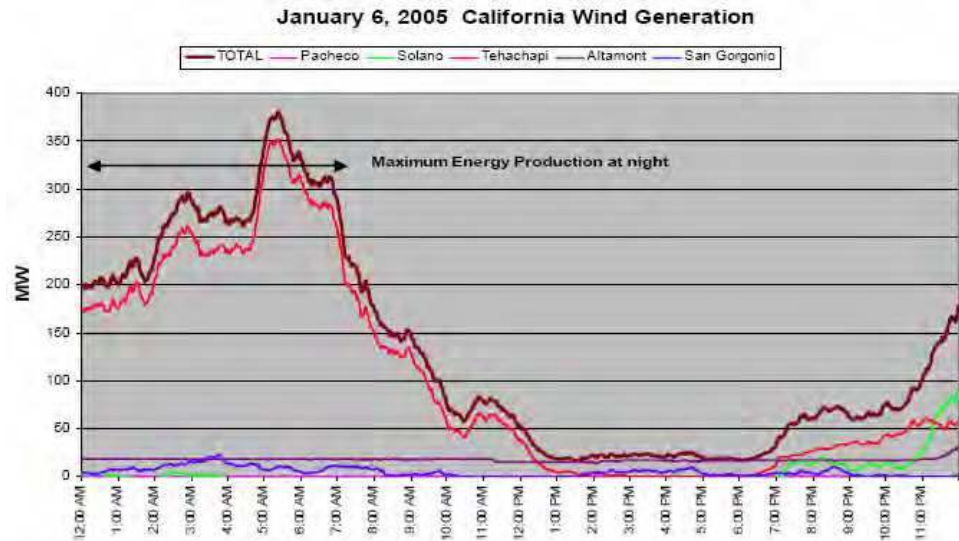

Fig. 19. California Wind Generation Jan. 2005

15. Projects in development

Several large CAES projects with different storage media are in development. Two are fully permitted and of particular note, even when the financial climate for new projects requiring major investments has slowed for such innovative concepts.

Storage Technology of Renewables and Green Energy Act of 2009 is funded by the US Department of Energy (DOE) to assist getting storage projects launched with Industry partnership. Load shifting for Wind Farm diurnal operations and ramping control to demonstrate CAES projects of 10 to 50 MW /2 to 5 hour storage will benefit from \$50/60 Million cost share.

Both above ground and below ground CAES projects will be considered for demonstration. It is expected that at least 35% lower CO₂ emissions than simple-cycle will be achieved, with a predicted economic payback based on the 24 months of project data. These projects must be ready for operation within 4 years of project award. Some of the larger projects in development could benefit from the US DOE serious consideration for energy storage based on increasing wind power generation.

15.1 Iowa Stored Energy Project (ISEP)

This project under development by Iowa Association of Municipal Utilities promises to be exciting and innovative. The compressed air will be stored in an underground aquifer and wind energy will be used to compress air in addition to available off-peak power. A separate section of the underground aquifer will be utilized for the storage of natural gas, allowing the CAES facility and other utilities to purchase gas when prices are lower.

The plant configuration is for 200 MW of CAES generating capacity, with 100 MW of wind energy. While wind might be the lowest cost generation system, it is variable and not reliable as a constant source. CAES provides the 'battery' storage for wind energy and makes wind energy a dispatch resource. CAES will expand the role of wind energy in the region generation mix and will operate to follow loads and provide capacity when other generation is unavailable or non-economic. The underground aquifer near Fort Dodge has the ideal dome structure allowing large volumes of air storage at 80 bar pressure or more with injection depth of 3000 feet (Fig. 20). With recent funding from the US DOE several exploratory wells have been drilled under the guidance of The Hydrodynamics Group team led by Michael King a natural gas engineer with 30 years of hydrogeology experience. The aquifer has been defined and additional test wells will need to be drilled prior to injection tests to determine the permeability of the sand stone. The results are promising thus far and further progress towards the first aquifer storage for air is well on the way.

Other states such as Illinois also have this potential for Wind & Storage. "Energy Storage Options for Central Illinois", (Makansi et al., 2003) but Iowa is in the forefront, possessing a site ideal for a CAES power plant and wind farm. These development plans have a future vision for the value of carbon reduction: adding reliable renewable resources with storage concepts such as CAES. In reality, there is no shortage of potential projects and suitable sites (van der Linden & Septimus, 2006) for Bulk Energy Storage development; there is no energy policy or incentive to implement the advantages and benefits demonstrated by NG Storage or the Pumped Hydro storage now serving the nation's power system. This long term lack of support is now getting some in-depth consideration from the US DOE driven by growing wind farm developments.

15.2 Project Markham, Texas

This 540 MW project in Matagorda County, Texas, developed by Ridge Energy Services, will consist of four 135 MW CAES units with separate LP and HP motor driven compression trains. The smaller 135 MW units in this project provide a very wide load range from 10 MW

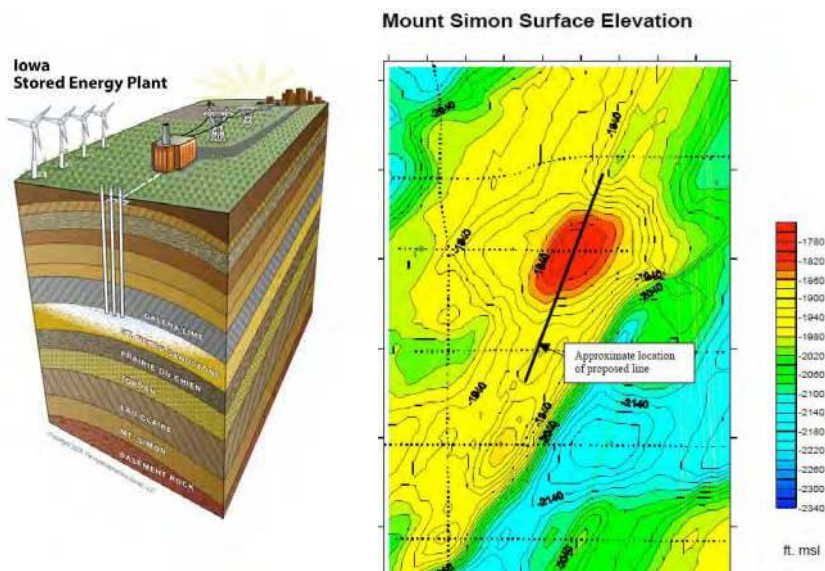

Fig. 20. Aquifer Air Storage Concept and the aquifer near Fort Dodge (Hydrodynamics Group)

minimum per unit and incremental output until all four units provide the system 540 MW. The full 540 MW can be delivered in less than 15 minutes. This is a tremendous value to the grid, providing reserve capacity, before cycling of base-loaded plant is required. The variable capacity range would be 840 MW (300 MW Compressor + 540 MW Generator). Nox emissions will be controlled to 5.0 vppm or lower with SCR in the HRU.

This site has Salt Dome cavern storage suitable for high pressure air storage and is unique in that natural gas storage is available on the site as well. This is ideal as energy can be arbitrated either as electrons (electricity) or Btu's (natural gas), or a combination of both.

Compression trains totaling 300 MW, for the required shorter off-peak charging period, will also act as a very large load sink on the system. This project stalled some years ago when funding for the project ceased due to financial circumstances, the same group contributed to a study commissioned by the Texas State Energy Conservation office, to look at the impact of CAES on Wind in Texas, Oklahoma and New Mexico. (Desai N, et al 2005)

The study results were positive in spite of very little day time to off-peak spark spread: "We have been working on combining compressed air energy storage (CAES) with wind generation in West Texas, and we have shown that storage can actually reduce the burden on the transmission system. In fact, storage can allow additional wind generation capacity to be served within an existing transmission plan. Our estimates suggest that a combined wind and storage project would be able to produce shaped, dispatchable energy for less than 5 cents per kWh with the capacity benefits of traditional thermal generation, with over 90 percent renewable content." "The conditions are different in 2009 and new developments are expected.

15.3 Norton Energy Storage, Ohio

One of the first potential CAES projects in the USA, developed by Haddington Ventures, Inc., is the huge facility at Norton in Ohio which is permitted for 2700 MW of capacity and

as a commercial project when completed will be one of the largest Bulk Energy Storage facilities, including PHS, to be built in the USA. As originally planned, this will consist of 9 x 300 MW (or larger) nominally rated CAES units supported by an underground storage cavern volume of 120 million cubic meters, 722 meters below the surface, originally mined in a limestone formation. Fig 21 attests to the dry cavern walls and height of the pillar and post mining creating the large storage capability.



Fig. 21. Norton Limestone Cavern (Hydrodynamics Group)

Using 200 MW (4 x 50 MW) compression trains for each 300 MW power train will allow for 16 hours generation by day for 5 days a week. Four units producing 1200 MW could operate for 4x16 hour days without requiring recharging of the cavern. With more available surface space, cavern volume could support 5400 MW or more for 8 to 10 hours operation, 5 days a week. This cavern was originally permitted for a PHS that would only support a small fraction of that capacity. The project has had many stops and starts, and is now once again being developed by Haddington using the McIntosh Turbo machinery arrangement with an up rated version of 135 MW modules; while this changes the dynamics of the original planning, it allows for lower initial investment. Decoupling the compressors from the power train will allow the compressors to be located away from the storage cavern, allowing more generating units to be located on the site, and so reach the full potential of this storage facility. With this modular approach, the capacity could be added over 5 years allowing full integration in Ohio and the East Central Area Reliability (ECAR) region.

16. What are the economics of CAES systems?

The best proof of the economics are to look at what Alabama Electric Cooperative (McIntosh CAES Plant 2600 MW /hr storage) are achieving as well as many different studies that have been conducted comparing CAES with current CCPP as well as IGCC and PC coal-fired power plants. Renewable energy such as Wind also demonstrates lower grid costs when integrated with CAES. Site and location specifics will obviously indicate different values and a comparison will have to be made for different regions considering “off-peak” power prices or “spilled” wind energy costs as well as the optimized benefits such as capacity value, transmission value, dispatch value, firming value, shaping value (wind), etc. The Total Operating costs for the CAES plant which includes charging costs as well as natural gas prices at \$6/MMBtu as provided by AEC and Electric Power Research Institute (EPRI) show a clear advantage for CAES with \$40/MWh when compared to Battery, Pumped Hydro and Gas Turbine plant; CAES power plants like Pumped Hydro have to consider the

storage volume and type of storage, such as solution mined caverns in salt domes (as done for NG), hard rock caverns, and aquifers or depleted gas wells. Solution mined caverns are the least costly and would add from \$50 to \$65/kW depending on the volume required (kW/hrs) to the overall installed cost (\$700/750/kW) which would be comparable or lower to a CCPP installation of equal size. In Texas, the economic impact of CAES could realize approx. \$10 Million per annum, integrating an additional 500MW of Wind just in one region. From a Pearl Street Executive Briefing Report, "Energy Storage, the Sixth Dimension of the Electricity Value Chain," the following excerpts are provided, indicating the possible economic impact utilizing Bulk Energy Storage: (www.energystoragecouncil.org).

According to a 1993 DOE Study, the direct impact of energy storage on the US power Industry is estimated at \$ 57.1 Billion based on wide spread us of "high density" storage devices. The potential value today with the increased generation and load requirements is estimated at \$174.4 Billion. Improving the operational efficiency of the generation segment holds a potential of \$10.5 Billion worth of positive economic impact over the next 15 years. By improving the operational efficiency of the transmission segment another \$ 29.9 Billion potential positive economic gain, is achievable over the next 15 years. The economic screening Analysis of Energy storage options with Gas Turbines and Combined Cycle plant by Electric Power Research Institute (EPRI) indicates that CAES plant is less expensive in levelized cost in \$/kW-yr as well as Batteries and Pumped Hydro with capacity factors higher than 3% indicated by the chart Fig. 22 below.

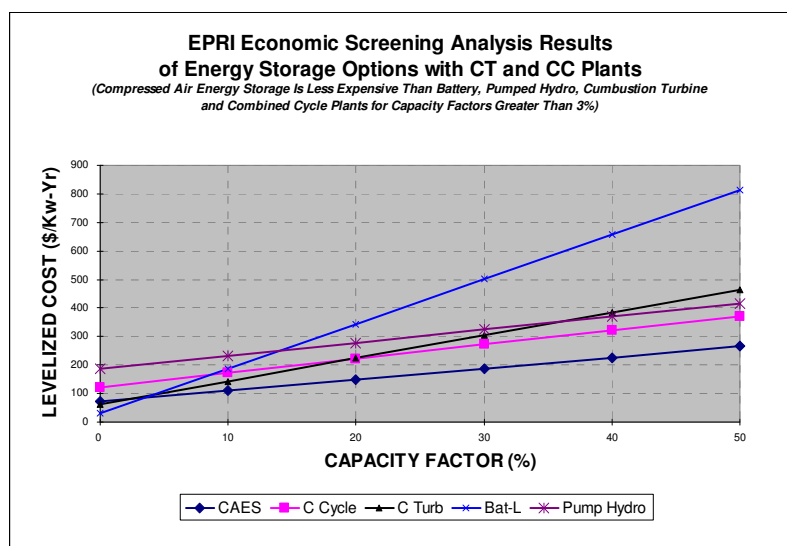

Fig. 22. EPRI Economic Screening Analysis of Energy Storage Options

The additional costs of energy storage when integrated with wind, often cited as being non-economic, is not born out by reality of the facts. Wind power for example by nameplate ratings are at \$2000/kW (or higher) for onshore installations, however when based on deliverable power capacity factors of 30% the equivalent cost to a base load plant now increases to \$4500/kW. CAES plant would add \$750/kW with the same fuel consumption as a Gas Turbine at \$350/kW. The CAES plant can readily improve the wind deliverable power

to 45% to 55% or higher reducing the basis of \$4500/kW to \$3000 and \$2500/kW respectively, the delta difference pays for the integrated CAES plant. This is a rough analysis as many other factors enter the actual economic screening.

17. Conclusions and recommendations

The current storage concepts are ready for deployment. Storage needs to be implemented in particular for Wind Energy, not just here in the US but in all developing countries. The biggest impact is probably the flexibility of operation. Economic dispatch to meet market needs, absorb excess capacity or large load swings with compression are powerful market tools. It is possible to improve energy management and obtain better value from bulk power purchase and sales; reduce risks and vulnerabilities from fuel price shocks. In particular, volatility in the US will always be a factor; long term projections show that natural gas prices will continue to rise with increased demand which cannot readily be met from new sources other than LNG imports.

The trend of increased harvesting of wind energy will put further stress on the grid reliability. This is already manifested in Europe where a far greater percentage of its generating base is committed to the variances of wind power production.

Most importantly, Bulk Energy Storage will "buffer" utilities from the lack of spinning reserve and load following capability, a result of many independent Wind Generating Farms installed in the last 5 years and substantial planned capacity. It will remove concerns about power quality and new threats to reliability. CAES as a generating asset has capacity value, as if it were a thermal asset, fully dispatchable, and a low emissions profile.

Using liquid air as an energy storage medium could be a potential solution to being able to locate storage for wind energy closer to load centers. This concept is proposed by Expansion Energy LLC. The Cryogenic tanks store liquid air are at relatively low pressure, which when required can be pumped at 42 bar to suit the prime mover, the liquid air is preheated and vaporized with the GT exhaust to feed an expander generating unit. Like many innovative concepts, ideas such as this will need further development and investigation for wind integration.

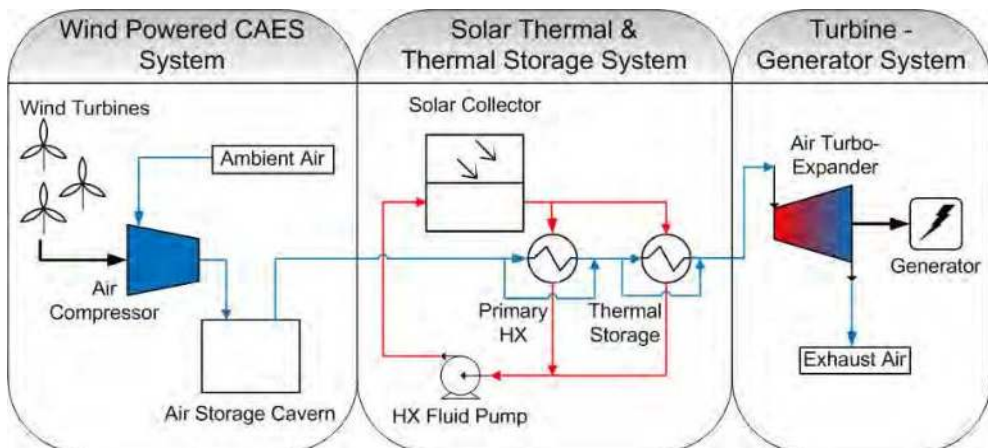

Fig. 23. Combined wind/solar thermal, using CAES & Thermal Storage (Courtesy Mark Kapner P.E. Austin Energy)

Eliminating the use of fossil fuel such as in adiabatic compression and expansion as discussed should get further attention and development funds for demonstration. Austin Energy in Texas has taken a step in this direction proposing the incorporation of Solar Energy in the thermal storage integrated with Wind and CAES as a Dispatchable Hybrid Wind / Solar Power Plant (Fig. 23); the study is being cooperatively supported by the University of Austin.

Energy Storage provides security, reduces transmission constraints, importantly extends (optimizes) the capabilities of efficient clean coal plants, reduces emissions, and primarily enhances and integrates wind energy as a valuable renewable resource. It provides load management, (rapid response) frequency and voltage control, spinning reserve, black start capabilities and supports distributed generation. Energy Storage and Wind integration will be a Paradigm shift in the entire Utility System

18. References

- Bulloch, Chris; Gatzert, Christoph; et al. (November 2004). "Advanced Adiabatic Compressed Air Energy Storage for the Integration of Wind Energy." Wind Energy Conference, EWEC 2004, London U.K.
- Enis, Dr. Ben; Lieberman, Dr. Paul; Rubin, Irving; van der Linden, Septimus. (June 2007). "Wind Turbine Generator and Compressed Air Energy Storage System for Production of Electrical Power and Co-generation of Chilled Air for Desalination." ECOS 2007, Padua, Italy.
- Desai, N; Gonzalez, S; Pemberton, D.J; and Rathjen, T.W. (June 2005) "The Economic Impact of CAES on Wind in TX, OK, and NM." Ridge Energy Storage & Grid Services L.P., Texas State Energy Conservation Office.
- Makansi, Jason; van der Linden, Septimus; Schien, Kent. (October 2003). "Energy Storage Options for Central Illinois."
- Electrical Energy Storage Applications & Technology (EESAT) Conference, San Francisco, CA.
- Nakhamkin, Michael; van der Linden, Septimus. (May 2000). "Integration of a Gas Turbine (GT) with Compressed Air Energy Storage (CAES) provides the best alternative for Mid Range and Daily Cyclic Generation Needs." ASME/IGTI Congress, Munich, Germany. Paper 2000-GT-82 Novel Concept ASME.
- Nakhamkin, Michael; van der Linden, Septimus; Wolk, Ronald; Patel, Manu. (June 2004). "New Compressed Air Energy Storage Concept Can Improve the Profitability of Existing Simple Cycle, Combined Cycle, Wind Energy, and Landfill Gas Combustion Turbine-based Power Plants." ASME /IGTI Congress, Vienna, Austria. Paper GT2004-54278.
- Van der Linden S. (April 2002). "CAES for Today's Market." EESAT Conference, San Francisco, CA.
- Van der Linden, Septimus. (2006). "Bulk Energy Storage potential in the USA, current developments and future prospects." Energy 31, 3446-3457, Science Direct.



Wind Power

Edited by S M Muyeen

ISBN 978-953-7619-81-7

Hard cover, 558 pages

Publisher InTech

Published online 01, June, 2010

Published in print edition June, 2010

This book is the result of inspirations and contributions from many researchers of different fields. A wide verity of research results are merged together to make this book useful for students and researchers who will take contribution for further development of the existing technology. I hope you will enjoy the book, so that my effort to bringing it together for you will be successful. In my capacity, as the Editor of this book, I would like to thanks and appreciate the chapter authors, who ensured the quality of the material as well as submitting their best works. Most of the results presented in to the book have already been published on international journals and appreciated in many international conferences.

How to reference

In order to correctly reference this scholarly work, feel free to copy and paste the following:

Septimus van der Linden (2010). Wind Power: Integrating Wind Turbine Generators (WTG's) with Energy Storage, Wind Power, S M Muyeen (Ed.), ISBN: 978-953-7619-81-7, InTech, Available from:
<http://www.intechopen.com/books/wind-power/wind-power-integrating-wind-turbine-generators-wtg-s-with-energy-storage>

INTECH

open science | open minds

InTech Europe

University Campus STeP Ri
Slavka Krautzeka 83/A
51000 Rijeka, Croatia
Phone: +385 (51) 770 447
Fax: +385 (51) 686 166
www.intechopen.com

InTech China

Unit 405, Office Block, Hotel Equatorial Shanghai
No.65, Yan An Road (West), Shanghai, 200040, China
中国上海市延安西路65号上海国际贵都大饭店办公楼405单元
Phone: +86-21-62489820
Fax: +86-21-62489821

© 2010 The Author(s). Licensee IntechOpen. This chapter is distributed under the terms of the [Creative Commons Attribution-NonCommercial-ShareAlike-3.0 License](#), which permits use, distribution and reproduction for non-commercial purposes, provided the original is properly cited and derivative works building on this content are distributed under the same license.